

Solutions for refrigeration and air conditioning technology

LOKRING[®] Connectors Type 00

Technical Documentation

Version 1.4

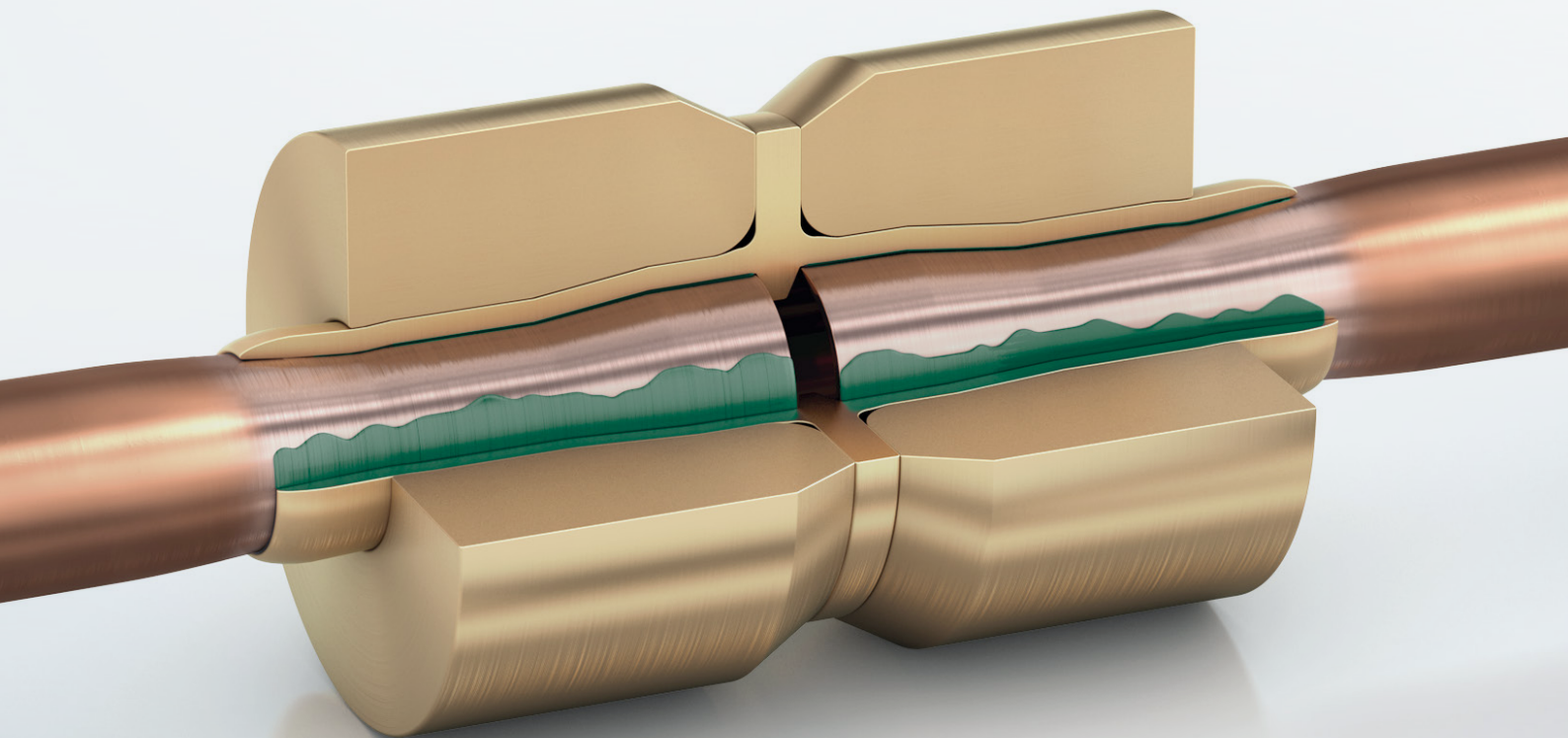

CONTENT

1.0	INTRODUCTION	03
2.0	AREAS OF APPLICATION	03
3.0	COMPONENTS OF A LOKRING® CONNECTION & ASSEMBLY TOOLS	03
4.0	FUNCTIONAL PRINCIPLE	04
5.0	LOKPREP® (ANAEROBIC SEALANT)	04
5.1	SPREADING THE LOKPREP®	05
5.2	CURING TIME	05
6.0	TECHNICAL SPECIFICATIONS AND APPROVALS OF THE LOKRING CONNECTION	05
7.0	PRODUCTS	06
7.1	STRAIGHT BRASS CONNECTORS	06
7.2	STRAIGHT ALUMINIUM CONNECTORS	07
7.3	STRAIGHT BRASS REDUCING CONNECTORS	08
7.4	STRAIGHT ALUMINIUM REDUCING CONNECTORS	10
7.5	T-REDUCING CONNECTORS	11
7.6	CONNECTORS WITH SCHRADER VALVES	12
7.7	STOPPERS	13
7.8	NAV CONNECTIONS	14
7.9	FILTER DRYERS	15
7.10	CHARGING TUBES	18
8.0	DECLARATION REGARDING PASSED TESTS	19
	ASSEMBLY INSTRUCTIONS	22
	LOKRING® TUBE CONNECTORS	22
	LOKRING® CAPILLARY REDUCING CONNECTORS	22
	LOKRING® T-REDUCING CONNECTORS	24
	LOKRING® PRE-ASSEMBLY FITTING VME	26
	LOKRING® NAV CONNECTION	28
	ONLINE-SERVICE	30
	VALIDITY CLAUSE	31

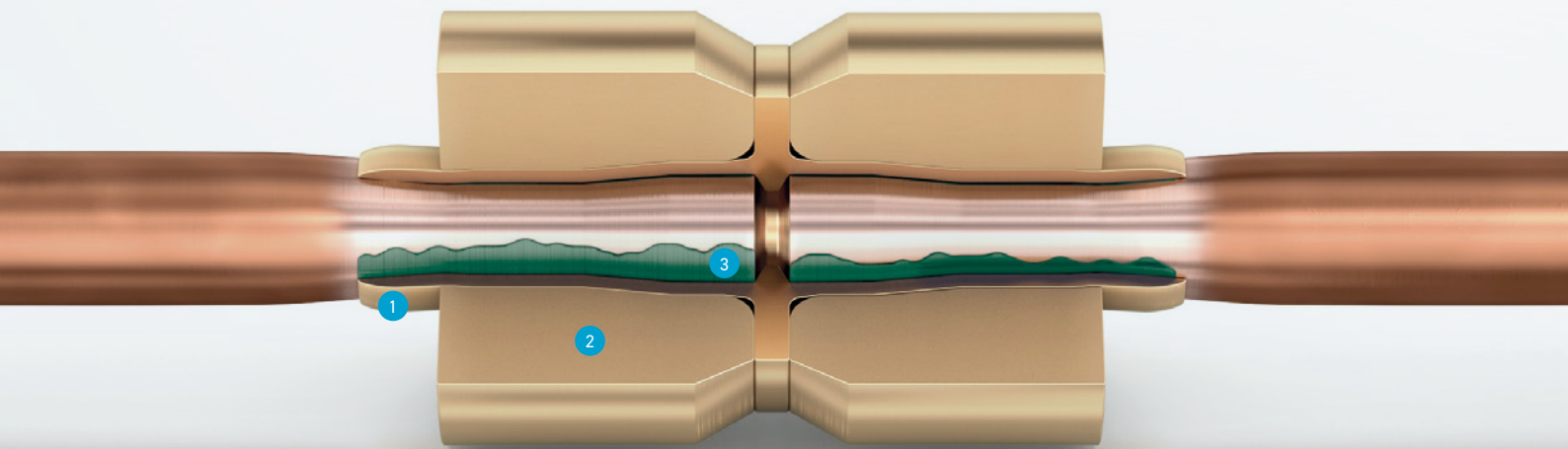

LOKRING® CONNECTORS TYPE 00

1.0 INTRODUCTION

The purpose of this document is to give technicians all information necessary about the solder-free LOKRING® tube connection technology in general and especially about LOKRING® connectors type 00.

2.0 AREAS OF APPLICATION

LOKRING® CONNECTORS TYPE 00 are being used in:

- ⊕ Household refrigeration appliances (refrigerators, freezers, wine coolers)
- ⊕ Ready-to-use refrigeration equipment (refrigeration cabinets, bars, lockers, chillers)
- ⊕ Refrigeration equipment for catering (sales counter, flow-through coolers, portable cooling systems)

3.0 COMPONENTS OF A LOKRING® CONNECTION & ASSEMBLY TOOLS



JOINT (1)
The shape of the joint to be used is defined by one of the many types, sizes and repair situations.

RING (2)
Rings are pre-assembled on the joint when delivered. Depending on the application, rings are made of steel brass or aluminium.



LOKPREP (3)
Is an important component of the LOKRING® connection technology. LOKPREP will compensate for any unevenness in the tube surface such as longitudinal grooves or surface porosity, thus ensuring that every LOKRING® connection is hermetically sealed.



LOKTOOL HMRK-V (4)
The LOKTOOL HMRK-V was developed for use in areas that are difficult to access. The handles of the HMRK-V are offset on both sides, allowing full use in places difficult to access.



LOKTOOL MB (5)
The assembly jaws can be replaced quickly and easily, thus making LOKRING® assembly possible with only one tool for different tube diameters. 2 different sizes are available to cover the whole diameter range from 1.6 to 11 mm (0.063" to 0.433").

LOKRING® CONNECTORS TYPE 00

4.0 FUNCTIONAL PRINCIPLE

The LOKRING® tube connection works on the basis of »simple« physical laws. It consists of two rings and one tubular joint which takes the two tube ends. During assembly, the tube ends are inserted into the joint to the inner limit. Then an assembly tool is used to push the two rings axially onto the joint. Due to the conical inner contour of the rings, the diameter of the joint is reduced during assembly so that the tube and the joint form a metallic hermetic connection through surface contact.

The lifetime gas-tightness of the fitted connection is ensured by the state of permanent elastic pre-tension, which is produced by the balance of the radial forces acting in opposite directions from tube to ring.

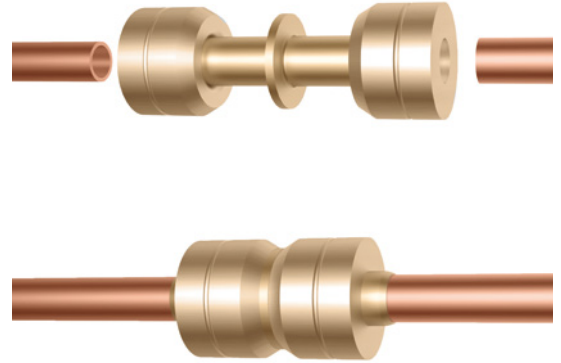

5.0 LOKPREP 65G (ANAEROBIC SEALANT)

Metal tubes can have longitudinal grooves on the surface from production. These production related faults can be compensated quite easily by moistening the tube ends to be connected with LOKPREP 65G fluid before assembly. Thanks to its capillary characteristic, it can even flow into microscopic cavities and fill these out completely. LOKPREP 65G is not an adhesive, rather an anaerobic sealant which hardens under oxygen exclusion and in contact with free metal ions. Its elastic structure is permanently retained in a temperature range of -50°C to 150°C (-58°F to 302°F), thus compensating material-specific deformations due to fluctuations in temperature. Since LOKPREP 65G does not contain solvents which have to evaporate during hardening, the finished connection is ready for use shortly after assembly.

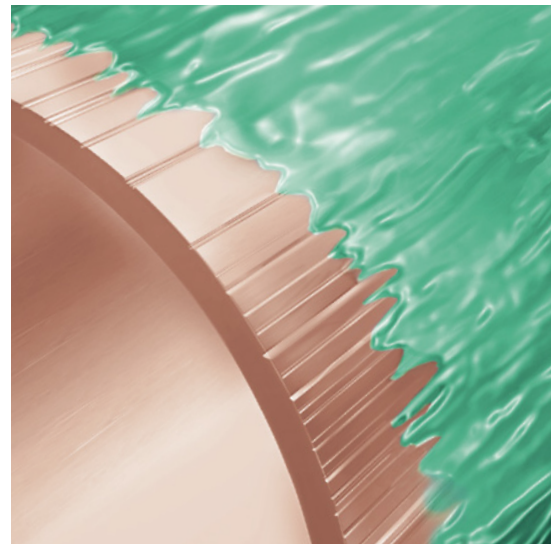

5.1 SPREADING THE LOKPREP 65G

Check the expiry date before applying LOKPREP 65G. Always make sure that the whole tube circumference is moistened with LOKPREP 65G.

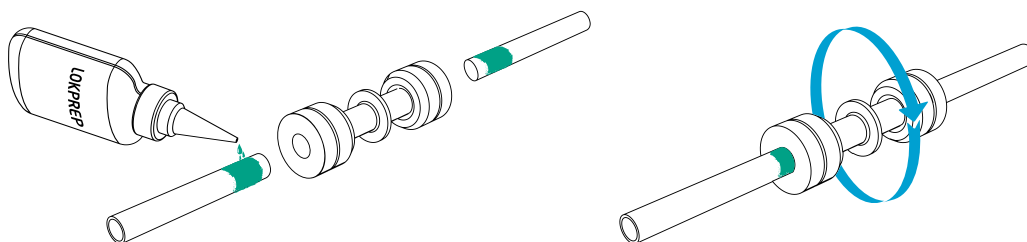

STEP 1
Apply LOKPREP 65G onto the metallic cleaned tube.

STEP 2
Rotate the joint through 360° around the end of the tubes.

5.2 CURING TIME

Always make sure that the LOKPREP 65G is properly cured before exerting any force on the LOKRING connection by moving, turning or bending the tube.

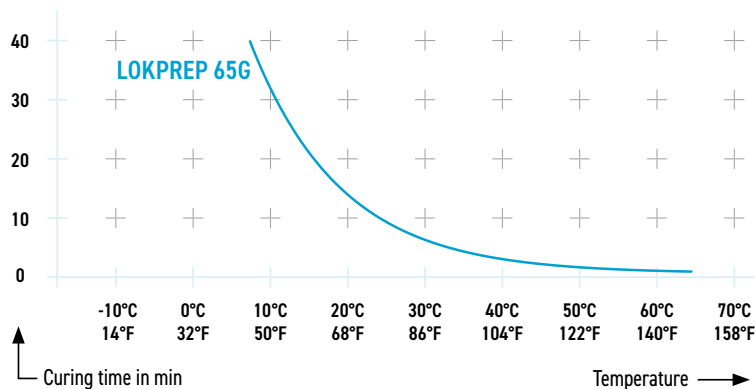

6.0 TECHNICAL SPECIFICATIONS AND APPROVALS FOR THE SERVICE CONNECTORS

Reference standards: EN 378-2 and ISO 14903
 Max. operating pressure: 25 bar (360 psi)
 Admissible refrigerants: Suitable for all HCs, HFCs and mixtures. Not suitable for NH₃.
 Temperature range: -50°C up to 150°C (-58°F up to 302°F)
 Tube diameter range of brass connectors: 1.6 to 11 mm (0.063" to 0.433")
 Tube diameter range of aluminium connectors: 1.8 to 9 mm (0.071" to 0.354")
 Minimum tube wall thickness: 0.5 mm (0.020")
 Approvals: TÜV, UL (File SA12004)

STRAIGHT CONNECTORS

7.0 PRODUCTS

7.1 STRAIGHT BRASS CONNECTORS

Please note: Both sides have the same dimensions (ODC/ODT/LID) and the shape / ring material of the connector can vary depending on size.

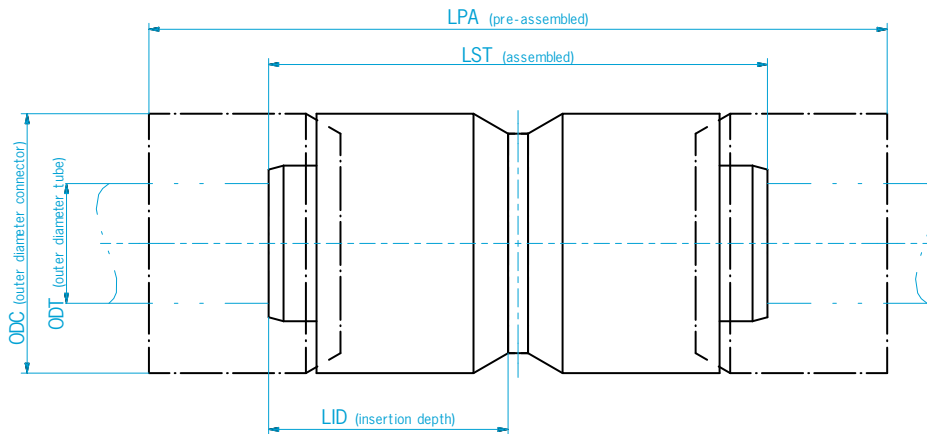

Article no.	Article name	Dimension					Notes	
		ODT		ODC	LID	LST		LPA (approx.)
		mm in		mm	mm	mm		mm
L13000575	LOKRING 1.6 NK Ms 00	1.6 - 1.7	0.063 - 0.067	13	17	35	40.5	
L13000932	LOKRING 1.8 NK Ms 00	1.8	0.071	13	17	35	40.5	
L13000576	LOKRING 2 NK Ms 00	1.9 - 2	0.075 - 0.079	13	17	35	40.5	
L13000578	LOKRING 2.2 NK Ms 00	2.2 - 2.3	0.087 - 0.091	13	17	35	40.5	
L13000579	LOKRING 2.5 NK Ms 00	2.4 - 2.5	0.094 - 0.098	13	17	35	40.5	
L13000580	LOKRING 3 NK Ms 00	3	0.118	13	12	25	36	
L13000582	LOKRING 3.2 NK Ms 00	3.2	0.126	13	12	25	36	
L13000584	LOKRING 4 NK Ms 00	4	0.157	13	12	25	37.5	
L13000587	LOKRING 5 NK Ms 00	4.76 - 5	0.187 - 0.197	13	12	25	37.5	
L13000588	LOKRING 6 NK Ms 00	6 - 6.35	0.236 - 0.250	13	12	25	38	
L13000589	LOKRING 6.5 NK Ms 00	6.5	0.256	13	12	25	37.5	
L13000590	LOKRING 7 NK Ms 00	7	0.276	14	12	25	37.5	
L13000591	LOKRING 7.5 NK Ms 00	7.5	0.295	14	12	25	37.5	
L13000592	LOKRING 8 NK Ms 00	8	0.315	14	12	25	37.5	
L13000595	LOKRING 9.53 NK Ms 00	9.53	0.375	16	13	27	44	
L13000596	LOKRING 10 NK Ms 00	10	0.394	16	13	27	44	

7.2 STRAIGHT ALUMINIUM CONNECTORS

Please note: Both sides have the same dimensions (ODC/ODT/LID) and the shape / ring material of the connector can vary depending on size.

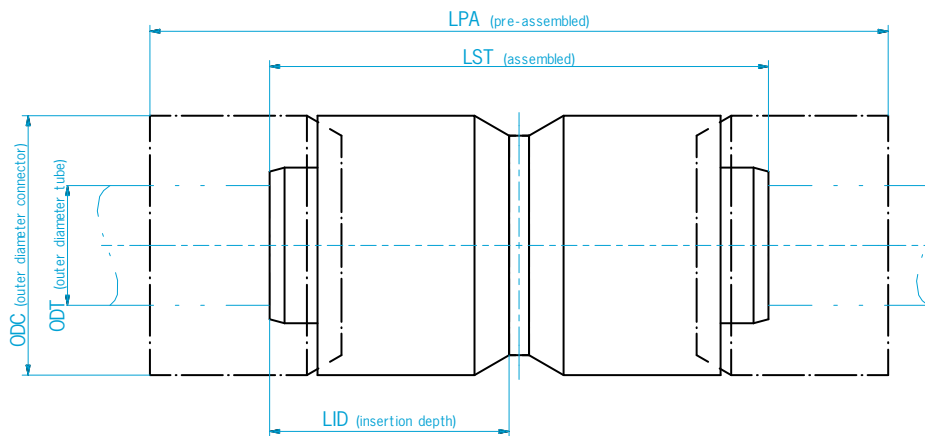

Article no.	Article name	Dimension					Notes	
		ODT		ODC	LID	LST		LPA (approx.)
		mm in	mm	mm	mm	mm		
L13000498	LOKRING 2 NK Al 00	1.9 - 2	0.075 - 0.079	13	19	39	43.5	
L13000502	LOKRING 5 NK Al 00	4.76 - 5	0.187 - 0.197	10	15.9	33	47	
L13000503	LOKRING 6 NK Al 00	6 - 6.35	0.236 - 0.250	13	15.9	33	46	
L13005631	LOKRING 7 NK Al 00	7	0.276	13	14.5	30.5	41	
L13005630	LOKRING 7.5 NK Al 00	7.5	0.295	13	14.5	30.5	41.5	
L13005625	LOKRING 8 NK Al 00	8	0.315	13	15	31.5	42.5	

STRAIGHT REDUCING CONNECTORS

7.3 STRAIGHT REDUCING CONNECTORS

Please note: The shape / ring material of the connector can vary depending on size.

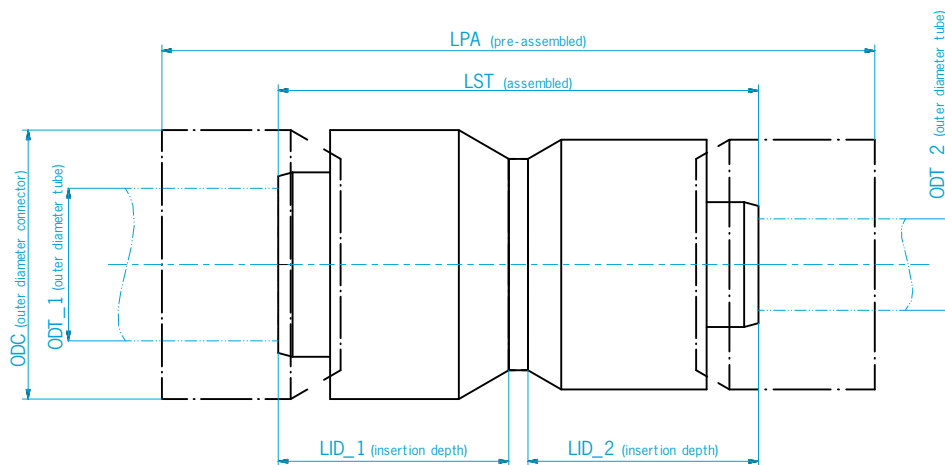

Article no.	Article name	Dimension								Notes
		ODT1		ODT2		ODC	LID_1	LID_2	LST	
		mm	in	mm	in	mm	mm	mm	mm	mm
L13003115	LOKRING 2/1.8 NR Ms 00	1.9 - 2	0.075 - 0.079	1.8	0.071	13	*	*	35	40.5
L13001157	LOKRING 3/1.8 NR Ms 00	3	0.118	1.8	0.071	13	11	*	30	38.5
L13000612	LOKRING 3/2 NR Ms 00	3	0.118	1.9 - 2	0.075 - 0.079	13	11	*	30	38.5
L13000931	LOKRING 4/1.8 NR Ms 00	4	0.157	1.8	0.071	13	11	*	30	39
L13000616	LOKRING 4/2 NR Ms 00	4	0.157	1.9 - 2	0.075 - 0.079	13	11	*	30	39
L13000618	LOKRING 5/1.6 NR Ms 00	4.76 - 5	0.187 - 0.197	1.6 - 1.7	0.063 - 0.067	13	11	*	30	39
L13000930	LOKRING 5/1.8 NR Ms 00	4.76 - 5	0.187 - 0.197	1.8	0.071	13	11	*	30	39

*see LOKRING Assembly instruction (capillary reducing connectors).

Article no.	Article name	Dimension									Notes				
		ODT1		ODT2		ODC	LID_1	LID_2	LST	LPA (approx.)					
		mm	in	mm	in	mm	mm	mm	mm	mm					
L13000619	LOKRING 5/2 NR Ms 00	4.76	- 5	0.187	- 0.197	1.9	- 2	0.075	- 0.079	13	11	*	30	39	*see LOKRING Assembly instruction (capillary reducing connectors).
L13000623	LOKRING 5/2.2 NR Ms 00	4.76	- 5	0.187	- 0.197	2.2	- 2.3	0.087	- 0.091	13	11	*	30	39	
L13000624	LOKRING 5/2.5 NR Ms 00	4.76	- 5	0.187	- 0.197	2.4	- 2.5	0.094	- 0.098	13	11	*	30	39	
L13000620	LOKRING 5/3 NR Ms 00	4.76	- 5	0.187	- 0.197	3		0.118		13	11.5	12	25	37	
L13000621	LOKRING 5/3.5 NR Ms 00	4.76	- 5	0.187	- 0.197	3.5		0.138		13	11.5	12	25	37	
L13000622	LOKRING 5/4 NR Ms 00	4.76	- 5	0.187	- 0.197	4		0.157		13	11.5	12	25	37.5	
L13001806	LOKRING 5/4.5 NR Ms 00	4.76	- 5	0.187	- 0.197	4.5		0.177		13	12	12	25	37.5	
L13002334	LOKRING 6/1.8 NR Ms 00	6	- 6.35	0.236	- 0.250	1.8		0.071		13	11	*	30	39.5	
L13000625	LOKRING 6/2 NR Ms 00	6	- 6.35	0.236	- 0.250	1.9	- 2	0.075	- 0.079	13	11	*	30	39.5	
L13000626	LOKRING 6/2.2 NR Ms 00	6	- 6.35	0.236	- 0.250	2.2	- 2.3	0.087	- 0.091	13	11	*	30	39.5	
L13000627	LOKRING 6/2.5 NR Ms 00	6	- 6.35	0.236	- 0.250	2.4	- 2.5	0.094	- 0.098	13	11	*	30	39.5	
L13000628	LOKRING 6/3 NR Ms 00	6	- 6.35	0.236	- 0.250	3		0.118		13	11.5	11.5	25	37	
L13000629	LOKRING 6/4 NR Ms 00	6	- 6.35	0.236	- 0.250	4		0.157		13	11.5	12	25	38	
L13000632	LOKRING 6/4.5 NR Ms 00	6	- 6.35	0.236	- 0.250	4.5		0.177		13	11.5	12	25	38	
L13000630	LOKRING 6/5 NR Ms 00	6	- 6.35	0.236	- 0.250	4.76	- 5	0.187	- 0.197	13	11.5	12	25	38	
L13000634	LOKRING 6.5/5 NR Ms 00	6.5		0.256		4.76	- 5	0.187	- 0.197	13	11.5	12	25	37.5	
L13000635	LOKRING 6.5/6 NR Ms 00	6.5		0.256		6	- 6.35	0.236	- 0.250	13	11.5	12	25	38	
L13000640	LOKRING 7/4 NR Ms 00	7		0.276		4		0.157		14	11.5	11.5	25	37.5	
L13000643	LOKRING 7/4.5 NR Ms 00	7		0.276		4.5		0.177		14	11.5	11.5	25	37.5	
L13000638	LOKRING 7/5 NR Ms 00	7		0.276		4.76	- 5	0.187	- 0.197	14	11.5	11.5	25	37.5	
L13000639	LOKRING 7/6 NR Ms 00	7		0.276		6	- 6.35	0.236	- 0.250	14	11.5	12	25	38	
L13000646	LOKRING 7.5/5 NR Ms 00	7.5		0.295		4.76	- 5	0.187	- 0.197	14	11.5	11.5	25	37.5	
L13000645	LOKRING 7.5/6 NR Ms 00	7.5		0.295		6	- 6.35	0.236	- 0.250	14	11.5	12	25	38	
L13000651	LOKRING 8/2 NR Ms 00	8		0.315		1.9	- 2	0.075	- 0.079	14	10	*	30	39	
L13000659	LOKRING 8/2.2 NR Ms 00	8		0.315		2.2	- 2.3	0.087	- 0.091	14	10	*	30	39	
L13000652	LOKRING 8/4 NR Ms 00	8		0.315		4		0.157		14	11.5	11.5	25	37.5	
L13000653	LOKRING 8/5 NR Ms 00	8		0.315		4.76	- 5	0.187	- 0.197	14	11.5	11.5	25	37.5	
L13000654	LOKRING 8/6 NR Ms 00	8		0.315		6	- 6.35	0.236	- 0.250	14	11.5	12	25	38	
L13000656	LOKRING 8/6.5 NR Ms 00	8		0.315		6.5		0.256		14	11.5	12	25	37.5	
L13000657	LOKRING 8/7 NR Ms 00	8		0.315		7		0.276		14	11.5	12	25	37.5	
L13000658	LOKRING 8/7.5 NR Ms 00	8		0.315		7.5		0.295		14	12	12	25	37.5	
L13000674	LOKRING 8.5/6 NR Ms 00	8.5		0.335		6	- 6.35	0.236	- 0.250	14	11.5	12	25	38	
L13000675	LOKRING 8.5/8 NR Ms 00	8.5		0.335		8		0.315		14	11.5	12	25	37.5	
L13000678	LOKRING 9/6 NR Ms 00	9		0.354		6	- 6.35	0.236	- 0.250	15	12	12	26	41	
L13000679	LOKRING 9/8 NR Ms 00	9		0.354		8		0.315		15	12.5	12	26	41	
L13000683	LOKRING 9.53/5 NR Ms 00	9.53		0.375		4.76	- 5	0.187	- 0.197	16	12	11.5	26	41	
L13000684	LOKRING 9.53/6 NR Ms 00	9.53		0.375		6	- 6.35	0.236	- 0.250	16	12	12	26	41	
L13000686	LOKRING 9.53/8 NR Ms 00	9.53		0.375		8		0.315		16	12.5	12	26	41	
L13000695	LOKRING 10/6 NR Ms 00	10		0.394		6	- 6.35	0.236	- 0.250	16	12	12	26	41	
L13000696	LOKRING 10/8 NR Ms 00	10		0.394		8		0.315		16	12.5	12	26	41	
L13000705	LOKRING 11/6 NR Ms 00	11		0.433		6	- 6.35	0.236	- 0.250	17	12.7	12	27	42	
L13000706	LOKRING 11/8 NR Ms 00	11		0.433		8		0.315		17	13	12	27	42	
L13000707	LOKRING 11/9.53 NR Ms 00	11		0.433		9.53		0.375		17	13.5	13	28	45	

STRAIGHT REDUCING CONNECTORS

7.4 STRAIGHT ALUMINIUM REDUCING CONNECTORS

Please note: The shape / ring material of the connector can vary depending on size.

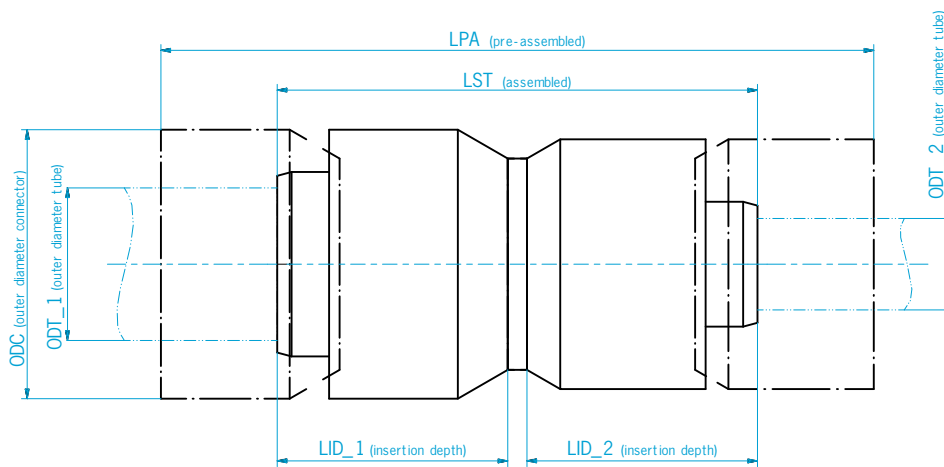

Article no.	Article name	Dimension								Notes
		ODT1		ODT2		ODC	LID_1	LID_2	LST	
		mm	in	mm	in	mm	mm	mm	mm	mm
L13001785	LOKRING 4/2 NR Al 00	4	0.157	1.9 - 2	0.075 - 0.079	10	16	*	36	45.5
L13002432	LOKRING 5/1.8 NR Al 00	4.76 - 5	0.187 - 0.197	1.8	0.071	10	16	*	36	45.5
L13002357	LOKRING 5/2 NR Al 00	4.76 - 5	0.187 - 0.197	1.9 - 2	0.075 - 0.079	10	16	*	36	45.5
L13000964	LOKRING 6/2 NR Al 00	6 - 6.35	0.236 - 0.250	1.9 - 2	0.075 - 0.079	12	16	*	38	47
L13000528	LOKRING 6/5 NR Al 00	6 - 6.35	0.236 - 0.250	4.76 - 5	0.187 - 0.197	12	15.8	16	33	46.5
L13005928	LOKRING 7/6 NR Al 00	7	0.276	6 - 6.35	0.236 - 0.250	13	14.5	15.7	32	44
L13005929	LOKRING 7.5/6 NR Al 00	7.5	0.295	6 - 6.35	0.236 - 0.250	13	14.5	15.7	32	44.5
L13005650	LOKRING 8/2 NR Al 00	8	0.315	1.9 - 2	0.075 - 0.079	13	15	*	37	45.5
L13005651	LOKRING 8/3 NR Al 00	8	0.315	4	0.157	13	15	15.9	33	46
L13005652	LOKRING 8/5 NR Al 00	8	0.315	4.76 - 5	0.187 - 0.197	13	15	16	33	46
L13005930	LOKRING 8/6 NR Al 00	8	0.315	6 - 6.35	0.236 - 0.250	13	15	15.7	32.5	45
L13005656	LOKRING 8/6.5 NR Al 00	8	0.315	6.5	0.256	13	15	14	31	42.5
L13005654	LOKRING 8/7 NR Al 00	8	0.315	7	0.276	13	15	14.5	31	42.5
L13005655	LOKRING 8/7.5 NR Al 00	8	0.315	7.5	0.295	13	15	14.5	31	43
L13005657	LOKRING 9/8 NR Al 00	9	0.354	8	0.315	15	16	15	32.5	44.5

*see LOKRING Assembly instruction (capillary reducing connectors).

T-REDUCING CONNECTORS

7.5 T-REDUCING CONNECTORS

Please note: The shape / ring material of the connector can vary depending on size.

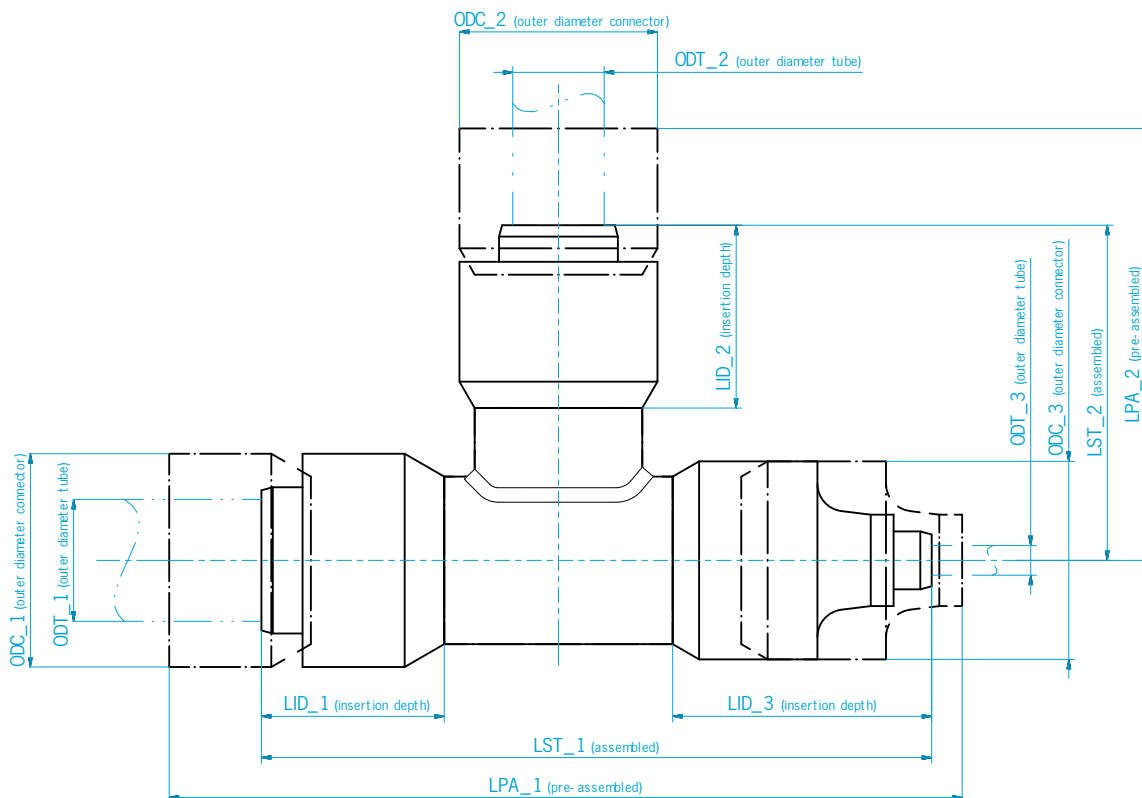

Article no.	Article name	Dimension															
		ODT1		ODT2		ODT3		ODC1	ODC2	ODC3	LID1	LID2	LID3	LST1	LST2	LPA1 (approx.)	LPA2 (approx.)
		mm	in	mm	in	mm	in	mm	mm	mm	mm	mm	mm	mm	mm	mm	
L13000748	LOKRING 7/6/2 NTR Ms 00	7	0.276	6 - 6.35	0.236 - 0.250	1.9 - 2	0.075 - 0.079	14	13	13	12	12	*	44	22	53	29
L13000750	LOKRING 7.5/6/2 NTR Ms 00	7.5	0.295	6 - 6.35	0.236 - 0.250	1.9 - 2	0.075 - 0.079	14	13	13	12	12	*	44	22	53	29
L13000751	LOKRING 8/6/2 NTR Ms 00	8	0.315	6 - 6.35	0.236 - 0.250	1.9 - 2	0.075 - 0.079	14	13	13	12	12	*	44	22	53	29

*see LOKRING Assembly instruction.

CONNECTORS WITH SCHRADER VALVES

7.6 CONNECTORS WITH SCHRADER VALVES

Please note: Both sides have the same dimensions (ODC/ODT/LID) and the shape / ring material of the connector can vary depending on size.

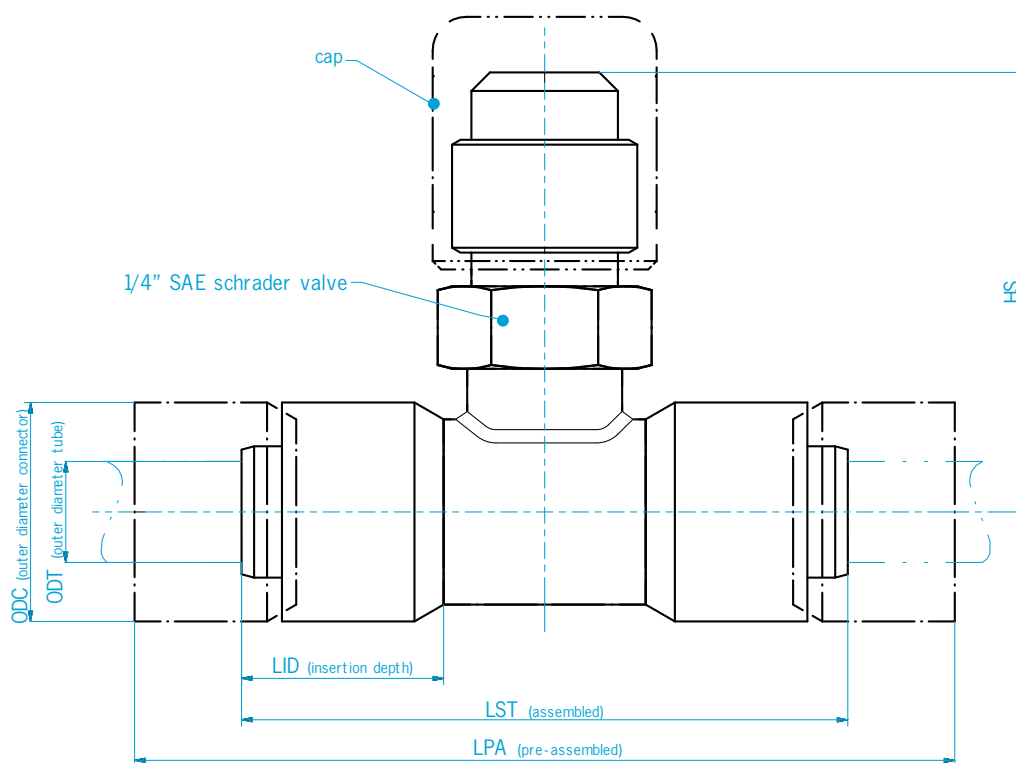

Article no.	Article name	Dimension							Notes
		ODT	ODC	LID	LST	LPA (approx.)	HS		
		mm in	mm	mm	mm	mm	mm		
L13000775	LOKRING 5 NK Ms SV 00	4.76 - 5	0.187 - 0.197	13	12	36	49	26.5	
L13000776	LOKRING 6 NK Ms SV 00	6 - 6.35	0.236 - 0.250	13	12	36	49	26.5	
L13000778	LOKRING 8 NK Ms SV 00	8	0.315	14	12	36	49	26.5	
L13000779	LOKRING 9.53 NK Ms SV 00	9.53	0.375	16	13	38	55	27.5	

STOPPERS

7.7 STOPPERS

Please note: The shape / ring material of the connector can vary depending on size.

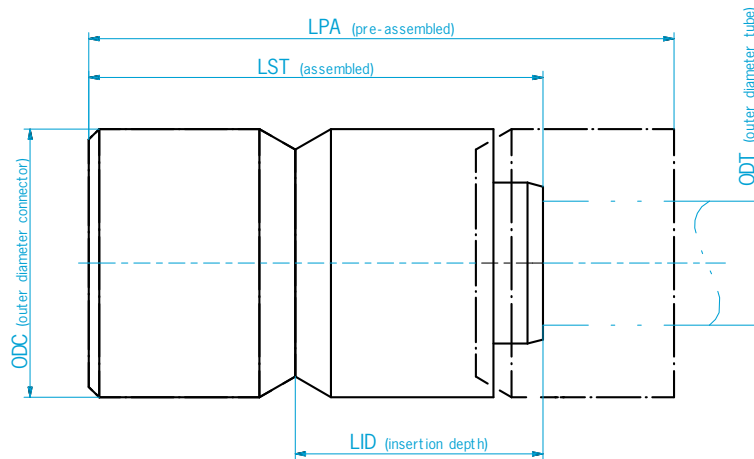

Article no.	Article name	Dimension					Notes
		ODT	ODC	LID	LST	LPA (approx.)	
		mm in	mm	mm	mm	mm	
L13000765	LOKRING 5 VS Ms 00	4.76 - 5	0.187 - 0.197	13	12	22	28
L13000766	LOKRING 6 VS Ms 00	6 - 6.35	0.236 - 0.250	13	12	22	29
L13000767	LOKRING 7 VS Ms 00	7	0.276	14	12	22	28
L13000769	LOKRING 8 VS Ms 00	8	0.315	14	12	22	28
L13000771	LOKRING 9.53 VS Ms 00	9.53	0.375	16	13	24	33

NAV CONNECTIONS

7.8 NAV CONNECTIONS

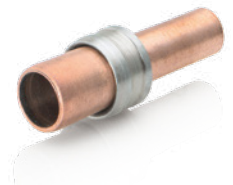
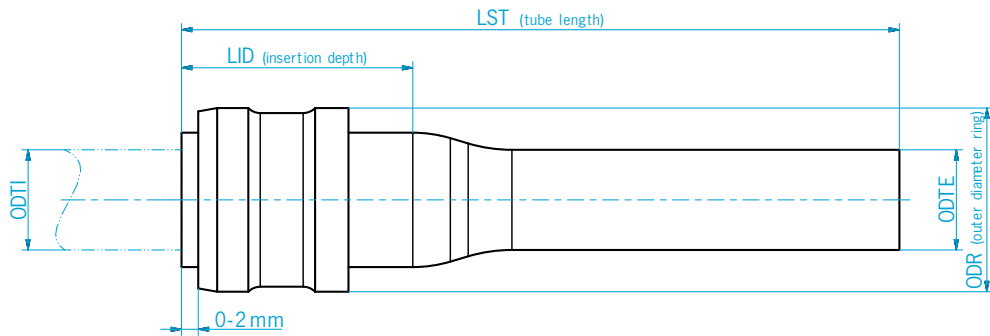

Article no.	Article name	Dimension						Notes	
		ODTI		ODTE		ODR	LID		LST
		mm	in	mm	in	mm	mm		mm
L13000817	LOKRING 6 NAV	6	0.236	6	0.236	11	15	43	
L13000818	LOKRING 7 NAV	7	0.276	7	0.276	13	15	43	
L13000819	LOKRING 7.5 NAV	7.5	0.295	8	0.315	13	15	43	
L13000820	LOKRING 8 NAV	8.25	0.325	8	0.315	13	15	43	
L13000926	LOKRING 9.53 NAV	9.53	0.375	9.53	0.375	15	15	50	

FILTER DRYERS

7.9 FILTER DRYERS

Desiccant: XH-9

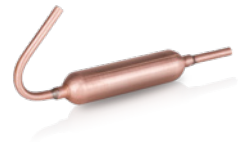
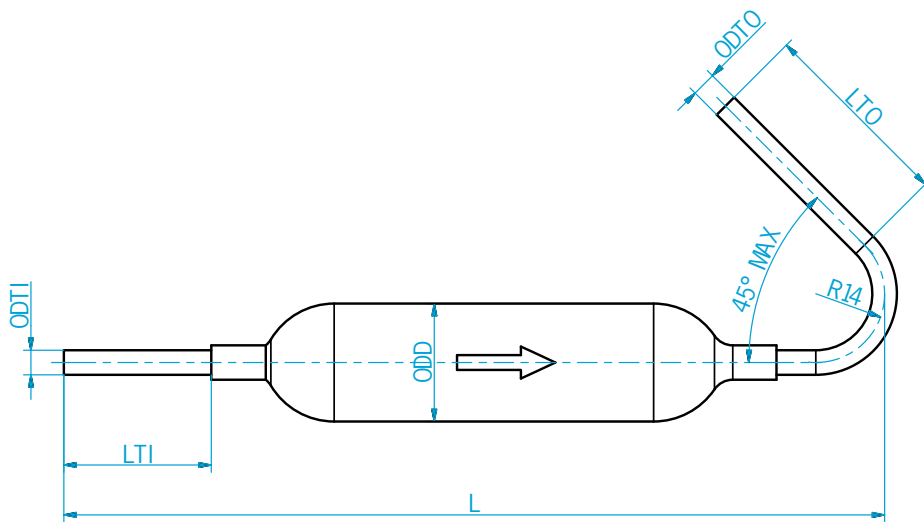

Article no.	Article name	Dimension								Notes
		ODTI	ODT0	ODTS	ODD	L (approx.)	LTI (approx.)	LTO (approx.)	LTS (approx.)	
		mm	mm	mm	mm	mm	mm	mm	mm	
L14000128	LOKRING DR 10	5	5	-	18.9	147	30	40	-	
L14000377	LOKRING DR 20	5	5	-	24	167	30	40	-	

FILTER DRYERS

Desiccant: XH-9

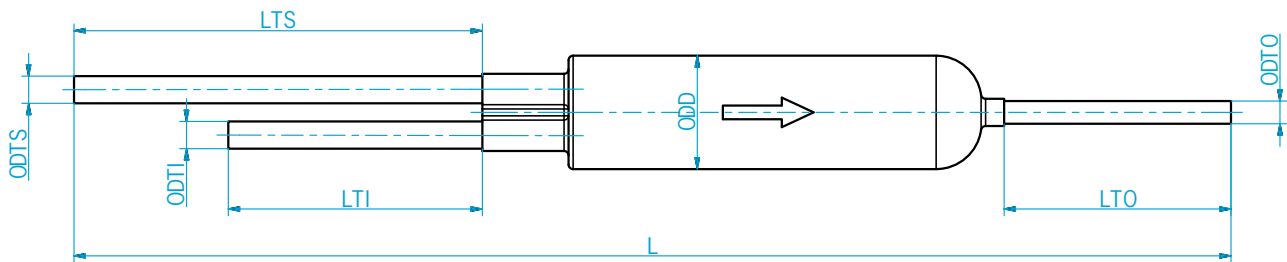

Article no.	Article name	Dimension								Notes
		ODTI	ODTO	ODTS	ODD	L (approx.)	LTI (approx.)	LTO (approx.)	LTS (approx.)	
		mm	mm	mm	mm	mm	mm	mm	mm	
L14000636	LOKRING DR 10-2E	5	5	6	25	245	50	50	90	
L14000611	LOKRING DR 15-2E	6	5	6	25	255	56	50	90	

Desiccant: XH-9

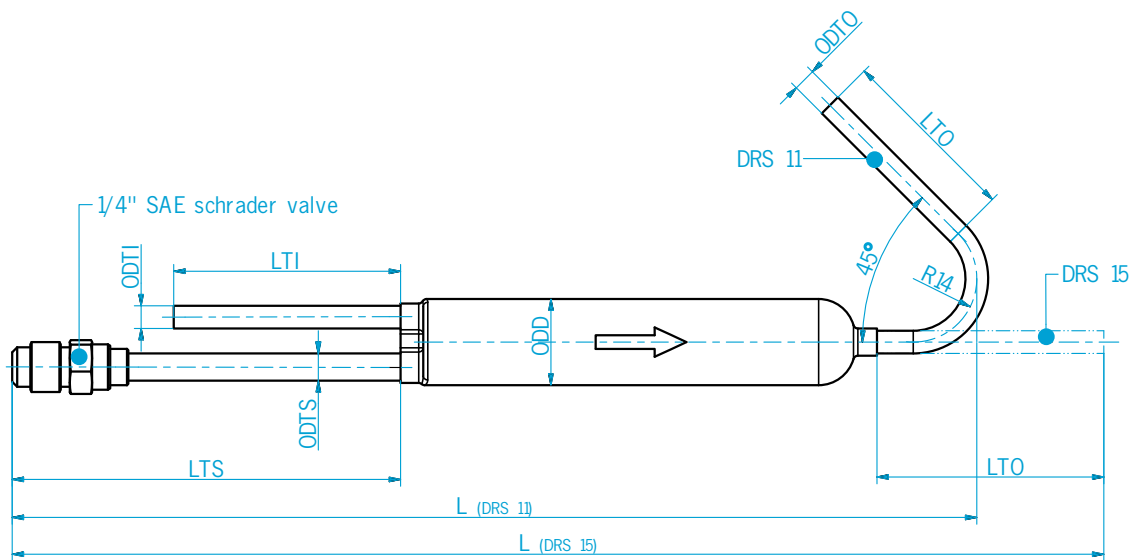

Article no.	Article name	Dimension								Notes
		ODTI	ODT0	ODTS	ODD	L (approx.)	LTI (approx.)	LTO (approx.)	LTS (approx.)	
		mm	mm	mm	mm	mm	mm	mm	mm	
L14002319	LOKRING DRS 11	5	5	6	19	213	50	40	88	
L14000118	LOKRING DRS 15	6	5	6	18.9	265	56	50	93	

CHARGING TUBES

7.10 CHARGING TUBES

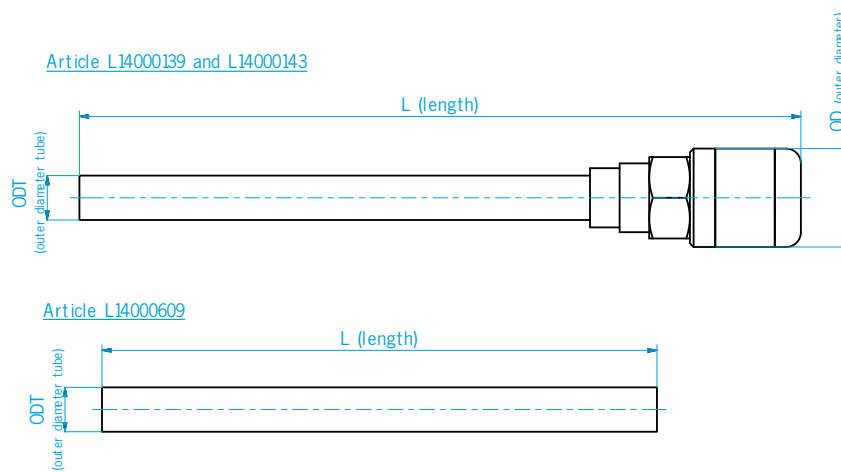

Article no.	Article name	Dimension			Notes	
		ODT		OD (approx.)		L (approx.)
		mm	in	mm		mm
L14000139	LOKRING 6 NF Ms SV 01*	6	0.236	13.3	330	* with schrader valve
L14000143	LOKRING 6 NF Ms SV-NG*	6	0.236	13.3	100	** without schrader valve
L14000609	LOKRING 6 NF Ms 00**	6	0.236	-	150	

DECLARATION REGARDING PASSED TESTS

8.0 DECLARATION REGARDING PASSED TESTS

VULKAN

Declaration regarding passed Tests according EN 16084:2011 (meanwhile replaced by ISO 14903:2017)

In the time frame of: July to October 2017

tests according to EN 16084:2011 have been performed on tube joints at the testing facilities of:

VULKAN Lokring
Rohrverbindungen GmbH & Co. KG
Heerstraße 66
44653 Herne, Deutschland

- > The joints consisted of: copper tube of following dimensions:
 \varnothing 2 mm (capillary tube); \varnothing 1/4" (6,35 mm) x 0,7 mm; \varnothing 10 mm x 0,7 mm
- as well as of: aluminium tube of following dimensions:
 \varnothing 2 mm (capillary tube); \varnothing 6 mm x 0,7 mm; \varnothing 8 mm x 0,5 mm
- joined by: LOKRING series 00 brass respectively aluminium connectors of appropriate size
- > using: LOKPREP 65G

As parameters an operating pressure of 25 bar and a temperature range of -40°C to 140°C have been chosen.

The test-plan according to the standard includes:

Tightness-test, preparatory
Vacuum-test
Pressure-temperature-test
Vibration-test
Freezing-test
Pressure-test
Fatigue-test
Tightness-test, terminatory

- > VULKAN Lokring Rohrverbindungen GmbH & Co. KG assures that all tests are performed carefully and according the actual interpretation of the standard and that the involved equipment is adequate for the performed tests.

The tested samples after running through the load tests have met the requirements of tightness control level A1 (hermetic joints, max. $7.5 \cdot 10^{-6}$ mbar·l/s He $\Delta p=10$ bar $T=20^\circ\text{C}$).

The choice of dimensions allows the transfer of the results to other series 00 connectors within the tested dimensions, provided that the wall thickness is above or equal to 0.6 mm.

25.01.2018 Thome
Date Development Manager

ASSEMBLY INSTRUCTIONS



LOKRING® tube connection assembly version 00

(The assembly version is determined on the basis of the last two figures in the article name. Example: LOKRING 6 NK Ms 00)

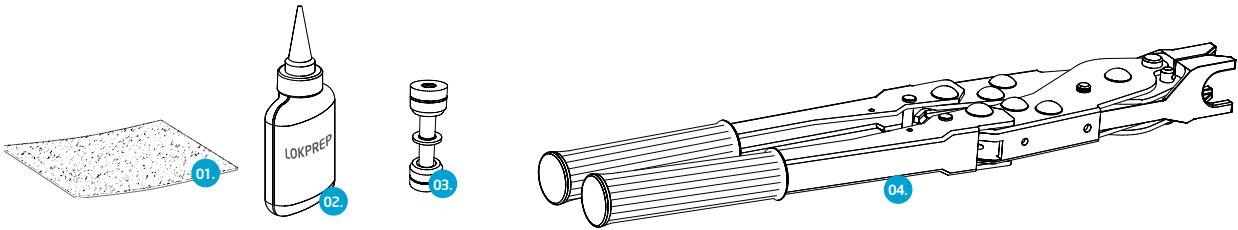

01. Emery cloth 02. LOKPREP 65G 03. LOKRING connector 04. Hand assembly tool

! Clean the tube ends in a rotational motion to ensure that they are clean and free from paint or other surface impurities.

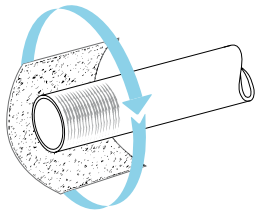

! Determine the outer tube diameter \varnothing using a digital caliper.

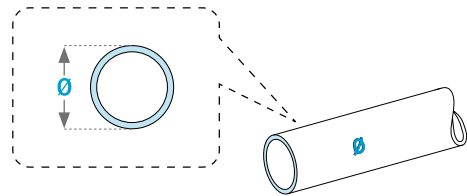

\varnothing = outer tube diameter

1 Apply LOKPREP 65G (02) onto the tube ends.

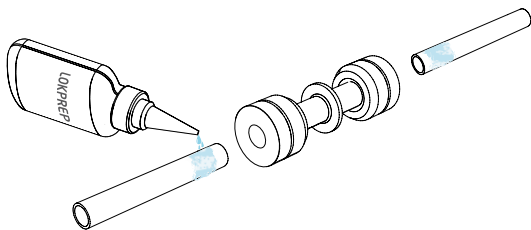

2 Insert both tube ends into the LOKRING connector (03) until the tubes reach the inner stop **!**. Rotate the LOKRING connector (03) through 360° to distribute the LOKPREP 65G (02) evenly. Respect the correct curing time of the LOKPREP 65G (02).

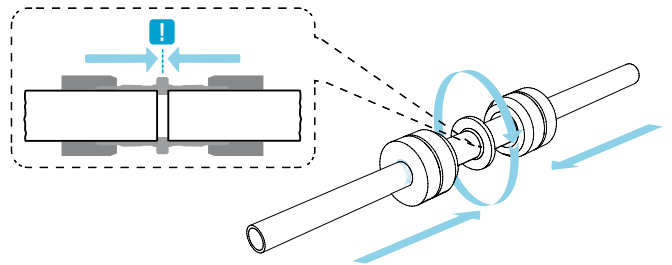

3 Position the jaws of the hand assembly tool (04) squarely onto the rings of the LOKRING connector (03). **!** In a controlled manner use the hand assembly tool (04) to press the rings onto the connector ensuring that the tubes remain seated against the centre stop of the LOKRING connector (03) throughout this process. Once both rings are flush to the centre stop of the connector the joint is complete. Carefully remove the hand assembly tool (04) from the LOKRING connector (03).

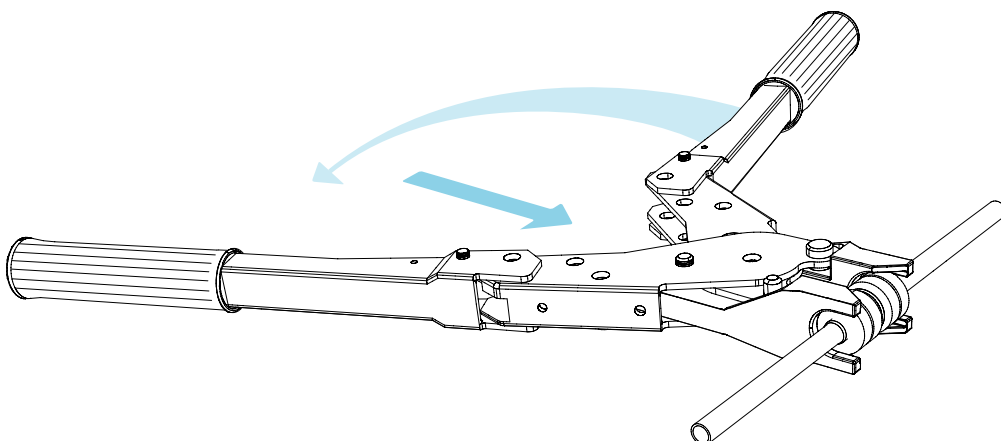
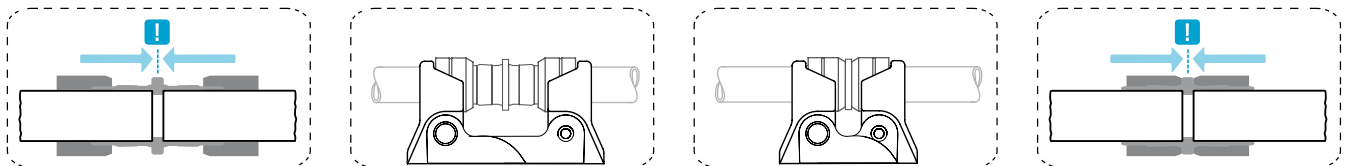

EXAMPLES AS ASSEMBLY AID

LOKRING® tube connection assembly version 00

! **Wrong:** Rings have not been pressed through to the assembly stop. **Right:** Rings have been pressed flush to the assembly stop.

! **Wrong:** The bending point is too close to the joint end. **Right:** The tube has to be led straightly out of the joint.

! **Wrong:** Assembly jaws are not set in place correctly. **Right:** Assembly jaws are set flush correctly.

! **Wrong:** The tube is not pushed in as far as the inner stop. **Right:** Push the tube in until you can feel the inner stop.

CURING TIME OF LOKPREP 65G

LOKRING® tube connection assembly version 00

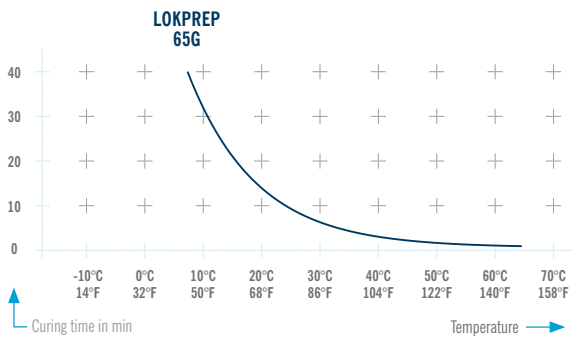

ASSEMBLY INSTRUCTIONS



LOKRING® tube connection assembly version 00 (capillary reducing connectors)

(The assembly version is determined on the basis of the last two figures in the article name. Example: LOKRING 5/2 NR Ms 00)

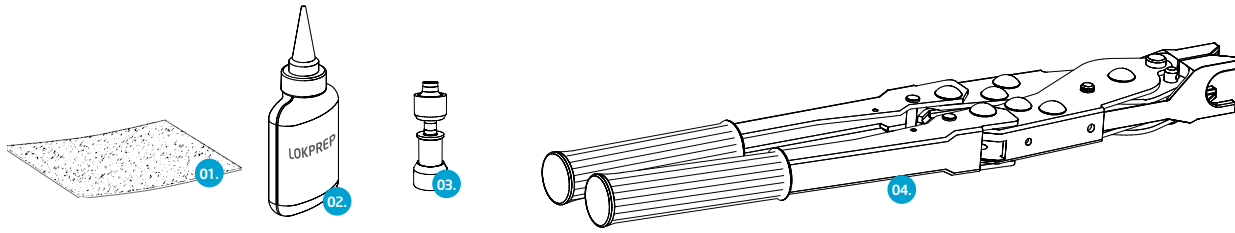

01. Emery cloth / Abrasive mat 02. LOKPREP 65G 03. LOKRING reducing connector 04. Hand assembly tool

! Clean the tube ends in a rotational motion to ensure that they are clean and free from paint or other surface impurities. For cleaning the capillary tube, abrasive mat (01) shall be used.

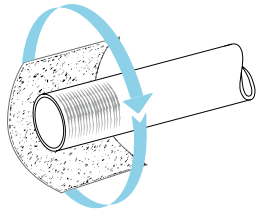

! Determine the outer tube diameter \varnothing using a digital caliper.

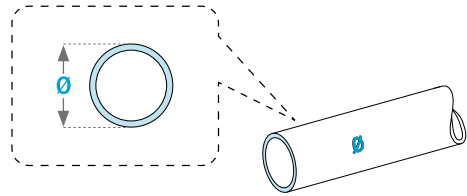

\varnothing = outer tube diameter

1 Push the LOKRING reducing connector (03) onto the capillary tube until approx. 20 mm of the tube protrude from the other side of the LOKRING reducing connector (03).

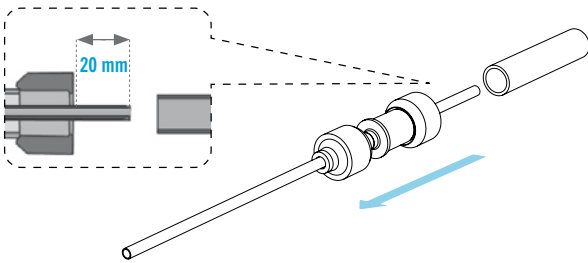

2 Bend the capillary tube slightly behind the LOKRING reducing connector (03) to mark the correct insertion depth. Insert the capillary tube protruding from the LOKRING reducing connector (03) into the second tube. Apply LOKPREP 65G (02) onto the tube.

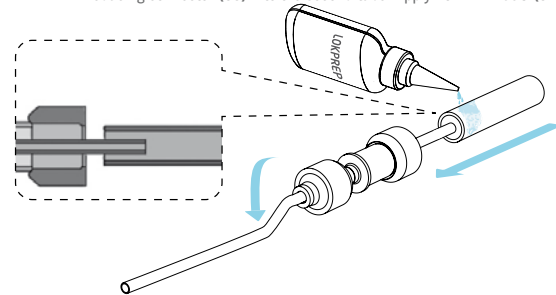

3 Pull the capillary tube approximately 10 mm out of the LOKRING reducing connector (03) and add LOKPREP 65G (02) behind the connector.

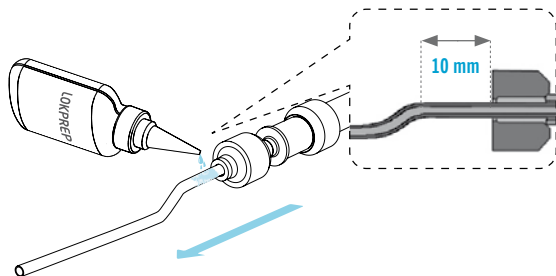

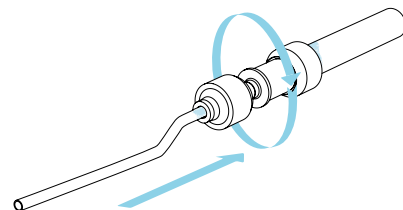

4 Insert both tubes into the LOKRING reducing connector (03). Rotate the LOKRING reducing connector (03) through 360° to distribute the LOKPREP 65G (02) evenly. Respect the correct curing time of the LOKPREP 65G (02).

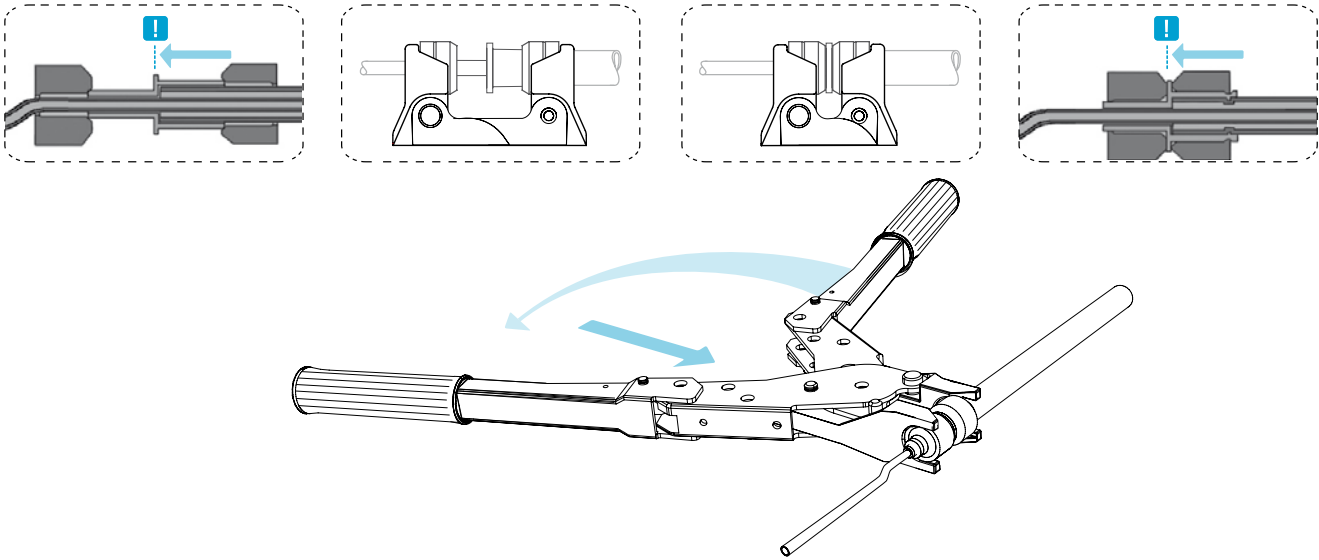

5 Position the jaws of the hand assembly tool (04) squarely onto the rings of the LOKRING reducing connector (03). **!** In a controlled manner use the hand assembly tool (04) to press the rings onto the connector ensuring that the insertion depth of the tubes does not change throughout this process. Once both rings are flush to the centre stop of the connector the joint is complete. Carefully remove the hand assembly tool (04) from the LOKRING connector (03).

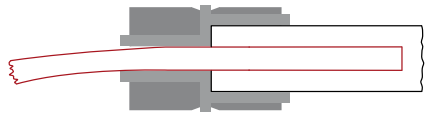
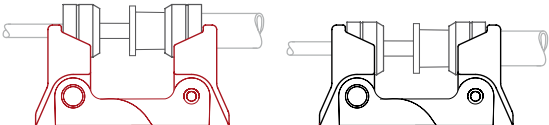

EXAMPLES AS ASSEMBLY AID LOKRING® tube connection assembly version 00 (capillary reducing connectors)

<p>! Wrong: Rings have not been pressed through to the assembly stop. Right: Rings have been pressed flush to the assembly stop.</p> 	<p>! Wrong: The bending point is too close to the joint end. Right: The tube has to be led straightly out of the joint.</p> 
<p>! Wrong: Assembly jaws are not set in place correctly. Right: Assembly jaws are set flush correctly.</p> 	<p>! Wrong: The tube is not pushed in as far as the inner stop. Right: Push the tube in until you can feel the inner stop.</p> 

CURING TIME OF LOKPREP 65G LOKRING® tube connection assembly version 00 (capillary reducing connectors)

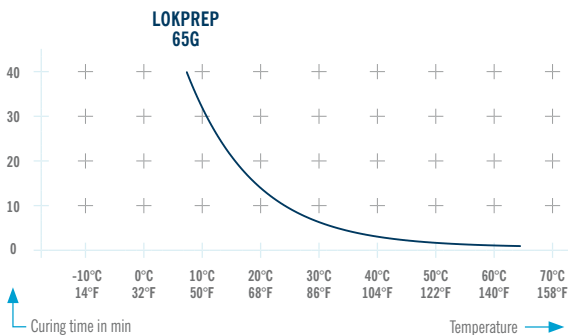

ASSEMBLY INSTRUCTIONS

Assembly of a LOKRING NTR connection type 00
(Repair of roll-bond condenser suction lines)

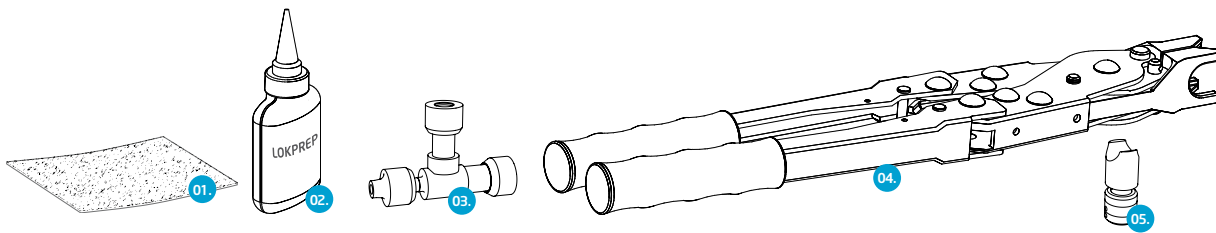

01. Emery cloth 02. LOKPREP 65G 03. LOKRING NTR connector 04. Hand assembly tool 05. Assembly fitting

1 Cut the suction line at the positions marked A, B and C.
A: Cut Cu suction line and capillary tube. **B:** Cut Cu suction line and capillary tube. **C:** Cut Al suction line only. Clean Al suction line in a rotational motion using emery cloth (01) before cutting to ensure it is clean and free from paint or other surface impurities. Distance between B and C has to be minimum 60 mm.

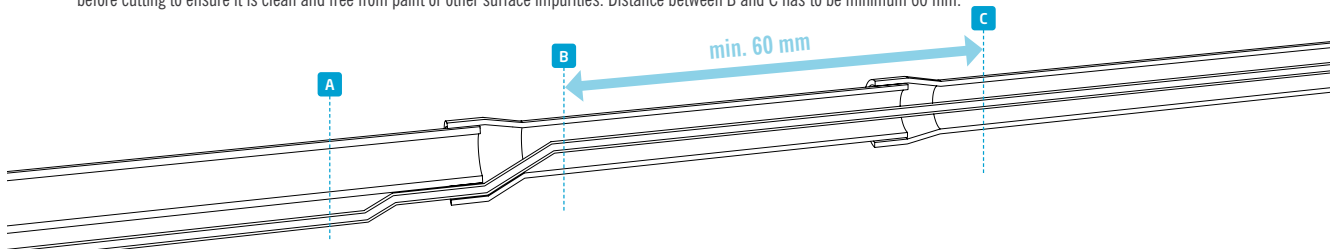

2 As a result, you get tubes 1, 2 and 3. Clean all tube ends in a rotational motion to ensure that they are clean and free from paint or other surface impurities. Clean the complete length of the capillary tube of tube 2.

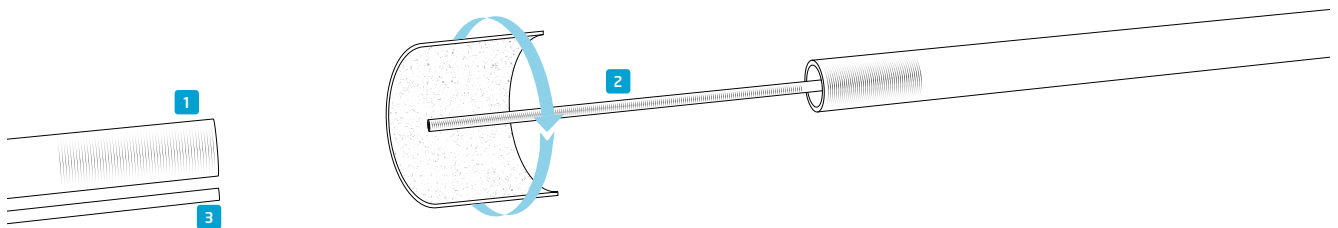

3 Apply LOKPREP 65G (02) onto the complete length of the insertion depths of the capillary tube and the Al suction line of tube 2.

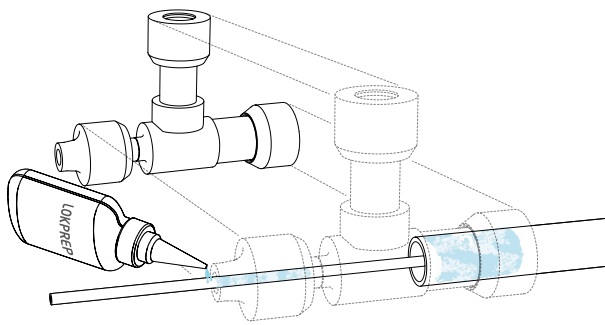

4 Push the LOKRING NTR connector (03) onto tube 2 and rotate the LOKRING NTR connector (03) through 360° to distribute the LOKPREP 65G (02) evenly. Respect the curing time of the LOKPREP 65G (02).

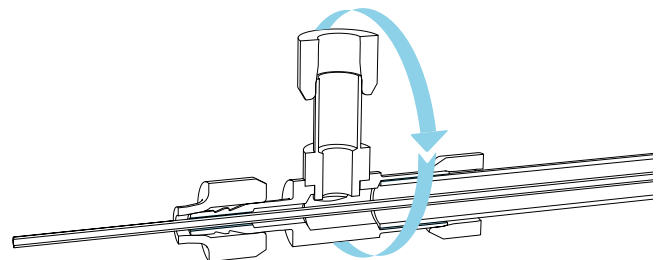

5 Position the jaws of the hand assembly tool (04) squarely onto the rings of the LOKRING NTR connector (03). In a controlled manner use the hand assembly tool (04) to press the rings onto the connector ensuring that the insertion depth of the tubes does not change throughout this process. Once both rings are flush to the centre stop of the connector the joint is complete, remove the hand assembly tool (04) from the LOKRING NTR connector (03).

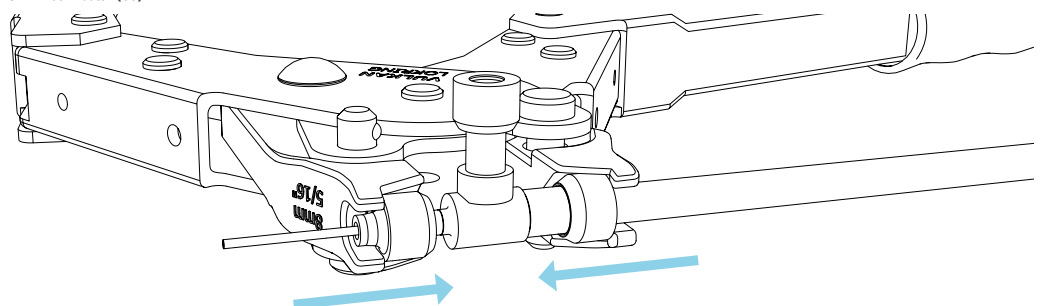

6 Insert the assembly fitting (05) into one jaw of the hand assembly tool (04).

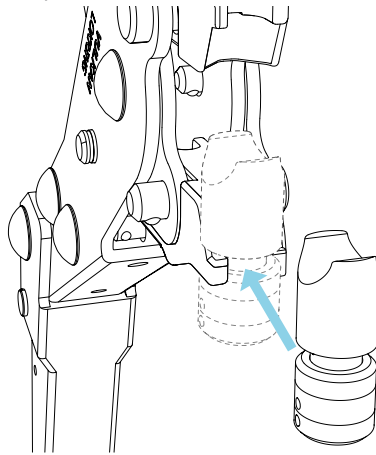

7 Apply LOKPREP 65G (02) onto the tube end of tube 1 (Cu suction line). Respect the curing time of the LOKPREP 65G (02).

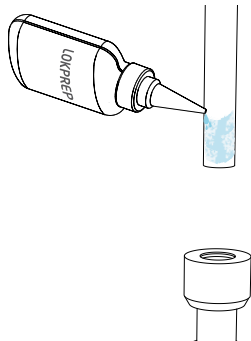

8 Insert tube 1 (Cu suction line) into the LOKRING NTR connector (03) until the tube reaches the inner stop.

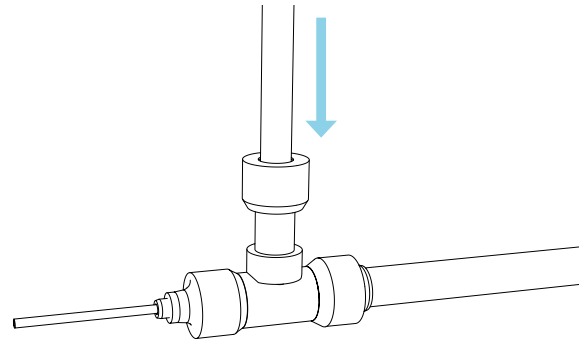

9 Position the hand assembly tool (04) in a way which ensures that the assembly fitting (05) is flush to the body of the LOKRING NTR connector (03) and the assembly jaw is squarely onto the ring of the LOKRING NTR connector (03). In a controlled manner use the hand assembly tool (04) to press the ring onto the connector ensuring that the tube remains seated against the centre stop of the LOKRING NTR connector (03) throughout this process. Once the ring is flush to the centre stop of the connector the joint is complete, carefully remove the hand assembly tool (04) from the LOKRING NTR connector (03).

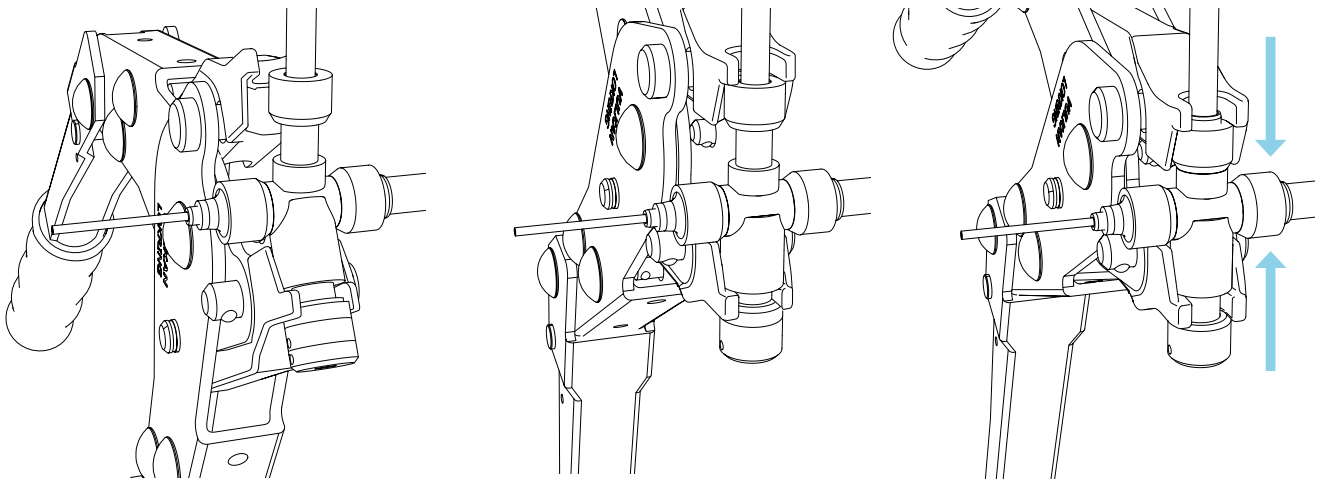

10 Connect tube 3 (capillary tube) according to the assembly instructions for LOKRING® tube connection assembly version 00 on www.vulkan.com.

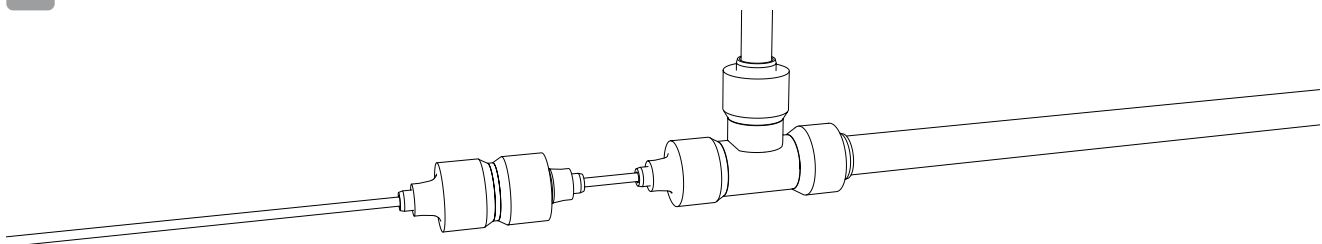

ASSEMBLY INSTRUCTIONS

Use of the pre-assembly fitting VME

The pre-assembly fitting allows for assembling a LOKRING connector or LOKRING reducing connector type 00 to only one of the tubes to be connected. This reduces the necessary space for making the final assembly considerably.

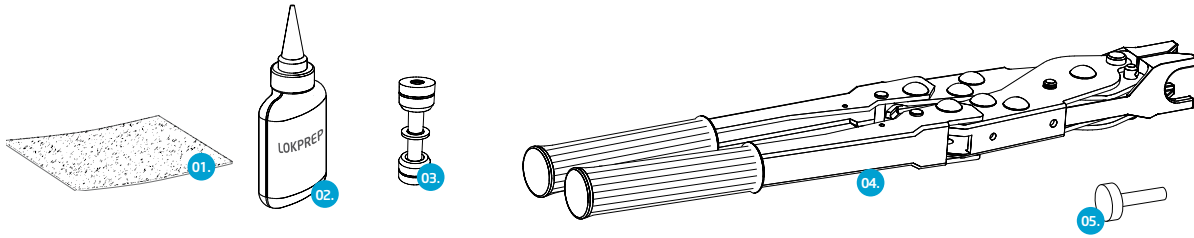

01. Emery cloth 02. LOKPREP 65G 03. LOKRING connector 04. Hand assembly tool 05. Pre-assembly fitting VME

1 Clean the tube end in a rotational motion with emery cloth (01) to ensure that they are clean and free from paint or other surface impurities. Apply LOKPREP 65G (02) onto the tube end.

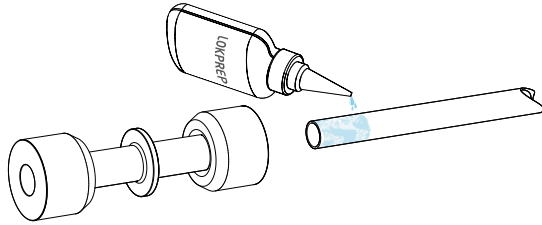

2 The smaller diameter tube should be connected first. In the event of connecting equal sized diameter tubing the softer material tube should always be connected first. In either case, insert the tube into the LOKRING connector (03) until the tube reaches the inner stop. **1** Rotate the LOKRING connector (03) through 360° to distribute the LOKPREP 65G (02) evenly. Respect the correct curing time of the LOKPREP 65G (02).

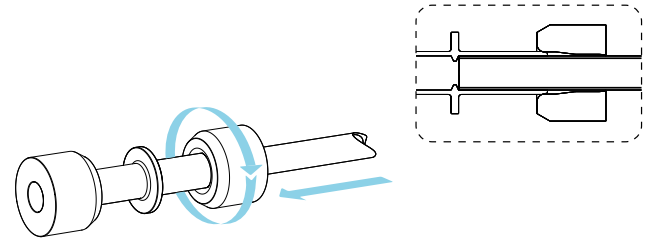

3 Insert the pre-assembly fitting (05) into the open side of the LOKRING connector (03) until it reaches the inner stop.

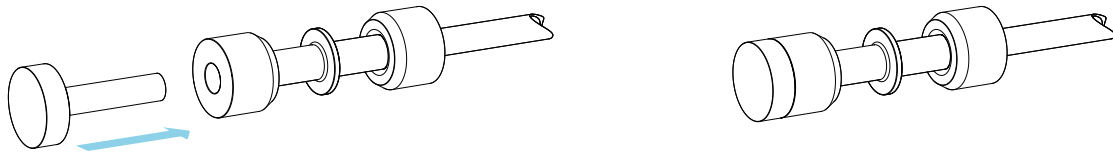

4 Put the assembly jaws of the hand assembly tool (04) in place behind the ring of the LOKRING connector (03) and the pre-assembly fitting (05).

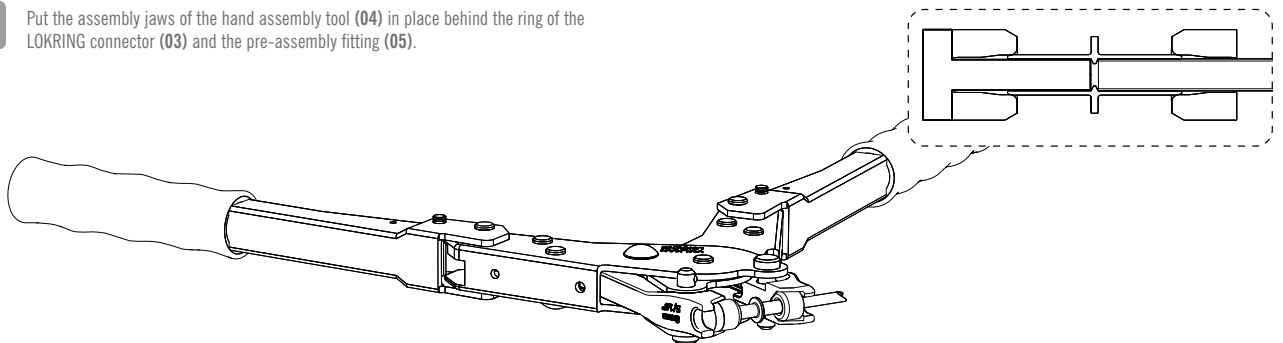

5 In a controlled manner use the hand assembly tool (04) to press the ring onto the connector ensuring that the tube remains seated against the centre stop of the LOKRING connector (03) throughout this process. **1** Note: Once the ring is flush to the centre stop of the connector the assembly is complete. Too much force can damage the connection! Carefully remove the hand assembly tool (04) from the LOKRING connector (03).

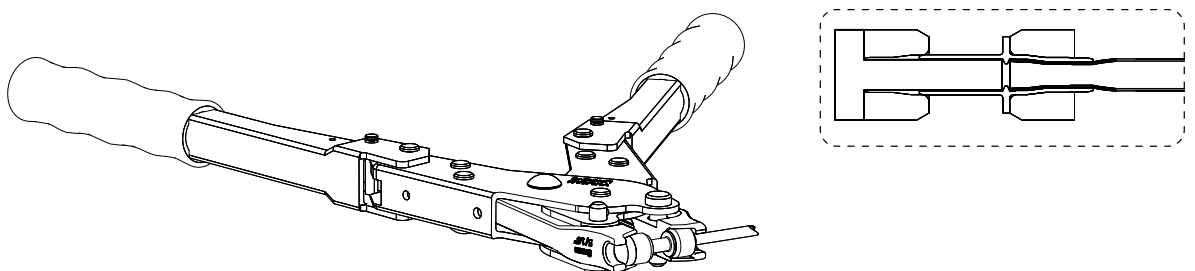

6

Finally, assemble the other side of the connection.

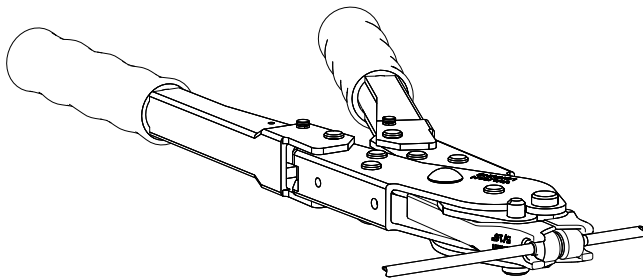
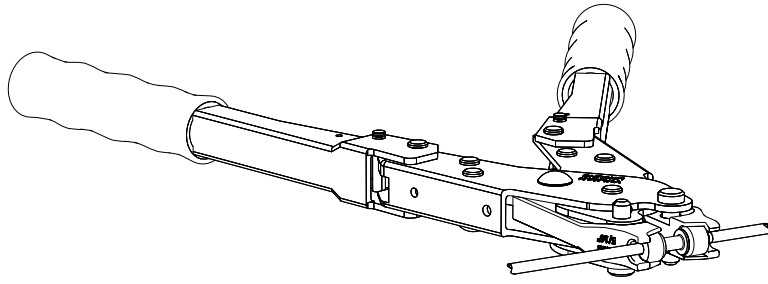

ASSEMBLY INSTRUCTIONS

Assembly of a LOKRING® NAV connection

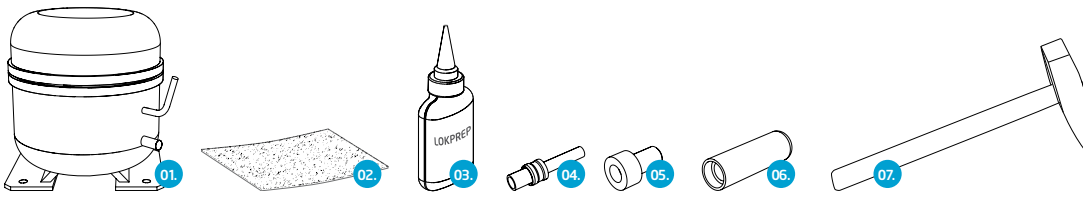

01. Compressor 02. Emery cloth 03. LOKPREP 65G 04. NAV connection 05. NAV assembly insert 06. NAV assembly tool 07. Hammer

1 The compressor stub length (X^1) must be straight, no longer than the flared section (Y^1) of the NAV connection (04) and not shorter than the length of the LOKRING that is to be used (Y^2) + 2 mm.

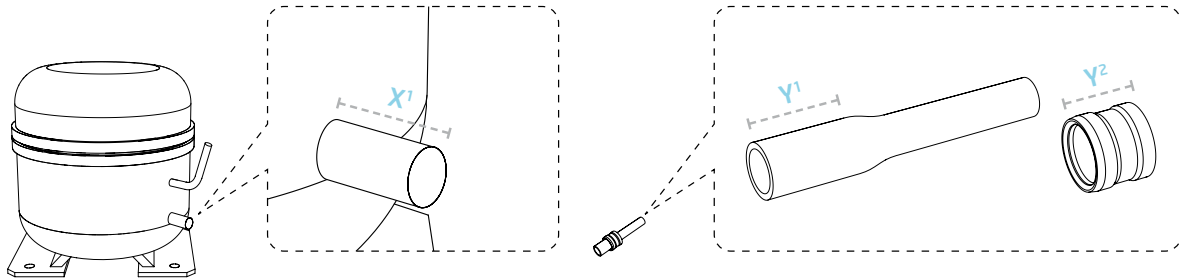

2 Clean the compressor stub length (X^1) in a rotational motion to ensure that it is clean and free from paint or other surface impurities.

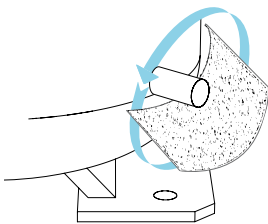

3 Apply LOKPREP 65G (03) onto the entire circumference of the compressor stub length (X^1), up to the cut edge. Respect the curing time of the LOKPREP 65G (03).

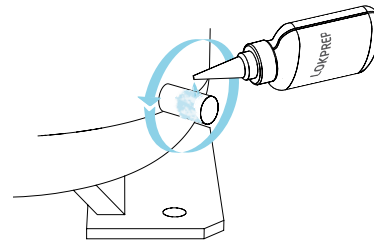

4 Determine the outer tube diameter \varnothing of the compressor stub (X^1) using a digital caliper. Select the appropriate NAV connection (04) and NAV assembly insert (05) according to the outer diameter of the compressor stub (X^1). Push the NAV connection (04) onto the compressor stub (X^1) and insert the NAV assembly insert (05) into the NAV assembly tool (06). Chamfer of the LOKRING must be oriented towards the compressor housing (01). Ensure that NAV connection (04) is touching the compressor housing (01).

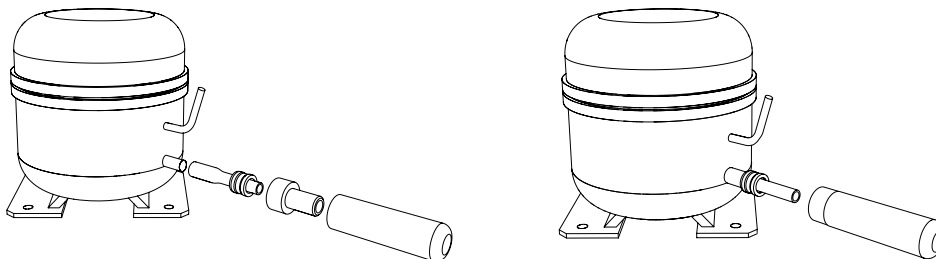

5 Strike the NAV assembly tool (06) with a hammer (07) until the LOKRING of the NAV connection (04) reaches the compressor housing (01).

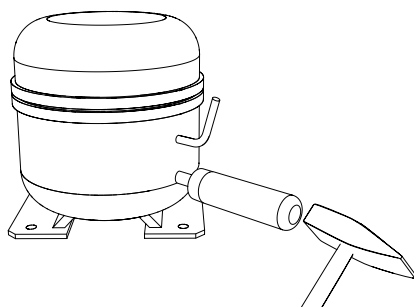

6 Carry out the LOKRING assembly with due regard to the assembly instructions for LOKRING connections type 00 at www.vulkan.com.

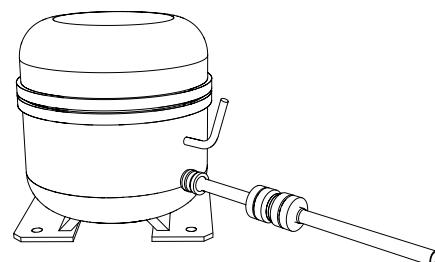

NOTES

A large grid of small dots for taking notes, consisting of 20 columns and 30 rows of dots.

ONLINE-SERVICE

FOR FURTHER INFORMATION, PLEASE REFER
TO OUR WEBSITE WWW.VULKAN.COM



AUTHORISED DISTRIBUTORS

www.vulkan.com/en-us/lokring/contact/



VIDEOS

www.vulkan.com/en-us/lokring/videos/



TECHNICAL DOCUMENTATION AND SUBMITTAL
[www.vulkan.com/en-us/lokring/downloads/
technical-documentation-and-submittal](http://www.vulkan.com/en-us/lokring/downloads/technical-documentation-and-submittal)



CATALOGUES & BROCHURES

www.vulkan.com/en-us/lokring/downloads/



CERTIFICATES

www.vulkan.com/en-us/lokring/downloads/certificates/

IMPRINT

PUBLISHER:

VULKAN Lokring
Rohrverbindungen GmbH & Co. KG
Heerstraße 66, 44653 Herne / Germany
Tel.: + 49 (23 25) 922-155
Mail: info.lok@vulkan.com

CONCEPT AND DESIGN:

Hackforth Holding GmbH & Co. KG
VULKAN Marketing
Heerstraße 66, 44653 Herne / Germany
Mail: marketing@vulkan.com

PREPRESS:

Hackforth Holding GmbH & Co. KG
VULKAN Marketing
Heerstraße 66, 44653 Herne / Germany
Mail: marketing@vulkan.com

VALIDITY CLAUSE

The LOKRING® tube connection technology represents a proven method of producing hermetically sealed metal-to-metal tube connections. The LOKRING® tube connections are mainly used in the refrigeration and air conditioning industries. The use of LOKRING® tube connection technology in other fields is to be discussed with VULKAN Lokring. VULKAN Lokring as the supplier is responsible for the qualitative delivery of the tube connections and tools which are ordered.

The purchaser is responsible for the use of the LOKRING® tube connections and tools as directed. The assembly has to be done accordingly to the instructions and exclusively with original LOKRING® parts. The present submittal shall replace all previous editions. The data contained in this submittal refers to the valid state of affairs in time of the copy deadline. Any changes due to technical progress are reserved.

Status: 01/2024

All duplication, reprinting and translation rights are reserved. Further remarks for the LOKRING® assembly are available on request.



www.vulkan.com/en-us/lokring/videos/