

ASSEMBLY INSTRUCTIONS

LOKRING® tube connection assembly version 00 (capillary reducing connectors)

(The assembly version is determined on the basis of the last two figures in the article name. **Example:** LOKRING 5/2 NR Ms 00)

VULKAN LOKRING

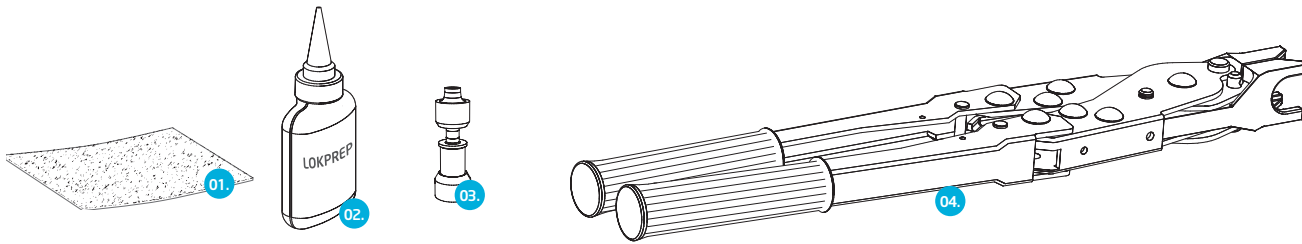

01. Emery cloth / Abrasive mat **02.** LOKPREP 65G **03.** LOKRING reducing connector **04.** Hand assembly tool

- !** Clean the tube ends in a rotational motion to ensure that they are clean and free from paint or other surface impurities. For cleaning the capillary tube, abrasive mat (01) shall be used.
- !** Determine the outer tube diameter \emptyset using a digital caliper.

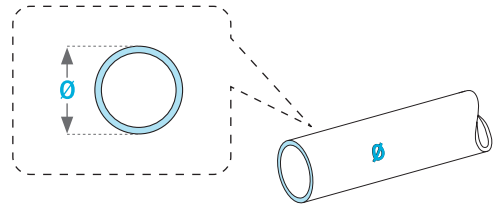
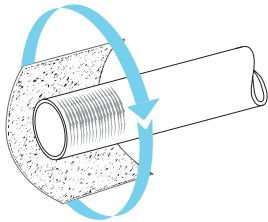

\emptyset = outer tube diameter

- 1** Push the LOKRING reducing connector (03) onto the capillary tube until approx. 20 mm of the tube protrude from the other side of the LOKRING reducing connector (03).

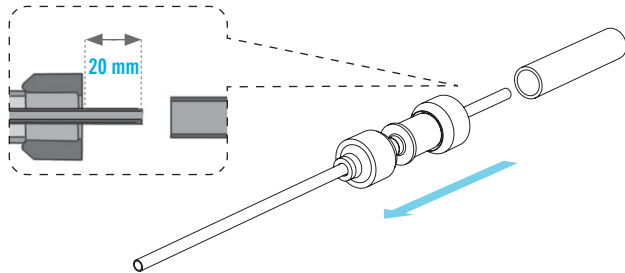

- 2** Bend the capillary tube slightly behind the LOKRING reducing connector (03) to mark the correct insertion depth. Insert the capillary tube protruding from the LOKRING reducing connector (03) into the second tube. Apply LOKPREP 65G (02) onto the tube.

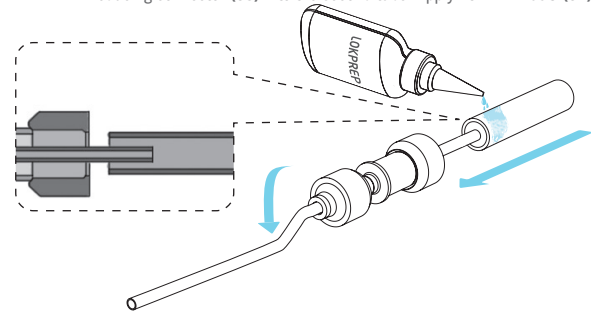

- 3** Pull the capillary tube approximately 10 mm out of the LOKRING reducing connector (03) and add LOKPREP 65G (02) behind the connector.

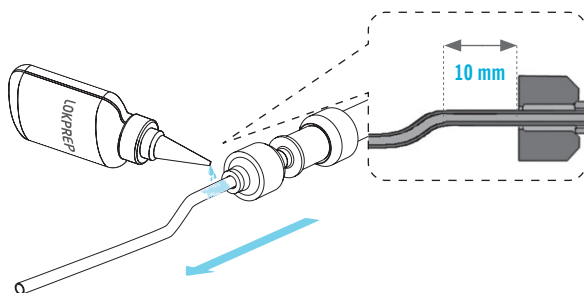

- 4** Insert both tubes into the LOKRING reducing connector (03). Rotate the LOKRING reducing connector (03) through 360° to distribute the LOKPREP 65G (02) evenly. Respect the correct curing time of the LOKPREP 65G (02).

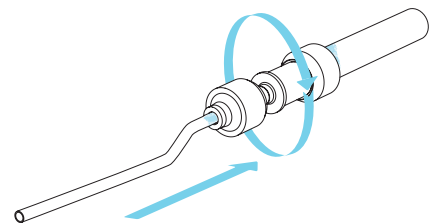

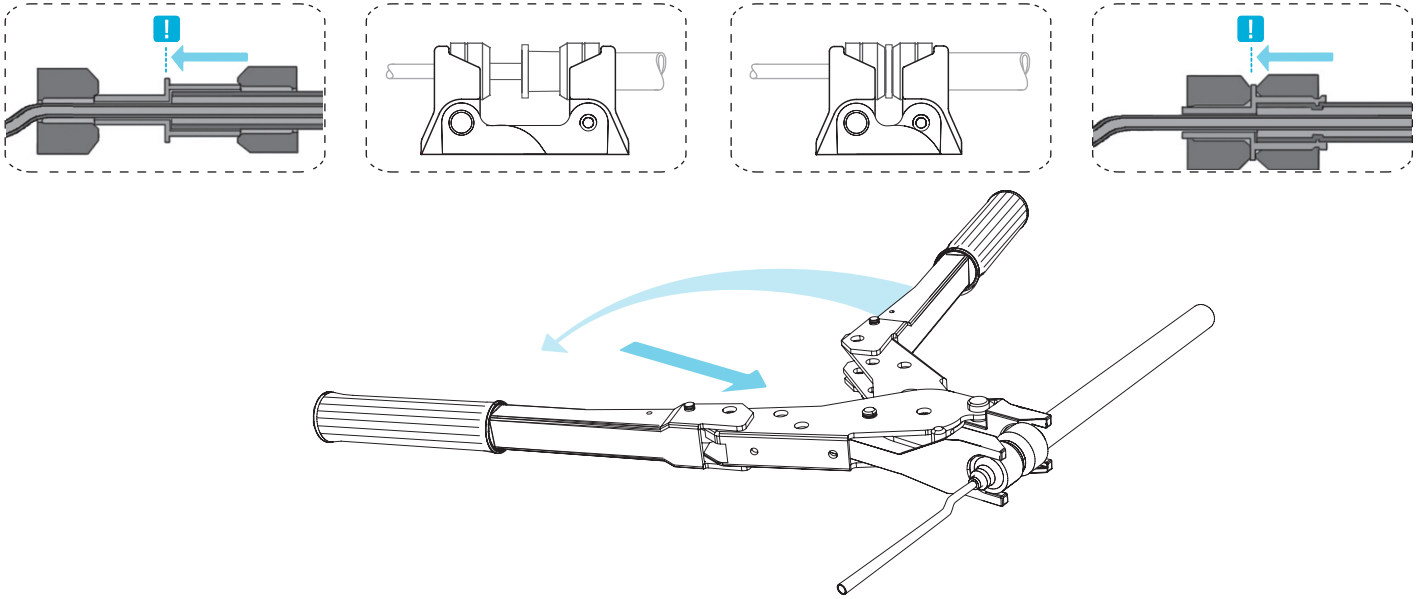

5

Position the jaws of the hand assembly tool (04) squarely onto the rings of the LOKRING reducing connector (03). **!** In a controlled manner use the hand assembly tool (04) to press the rings onto the connector ensuring that the insertion depth of the tubes does not change throughout this process. Once both rings are flush to the centre stop of the connector the joint is complete. Carefully remove the hand assembly tool (04) from the LOKRING connector (03).

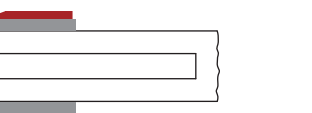
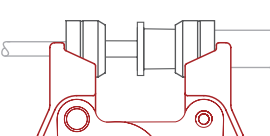
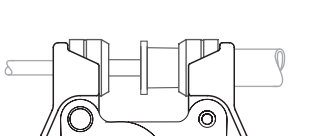
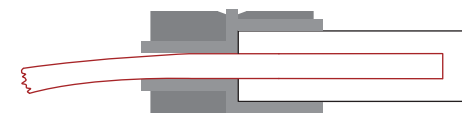
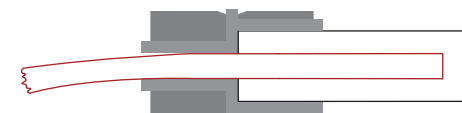

EXAMPLES AS ASSEMBLY AID LOKRING® tube connection assembly version 00 (capillary reducing connectors)

<p>! Wrong: Rings have not been pressed through to the assembly stop.</p> 	<p>Right: Rings have been pressed flush to the assembly stop.</p> 
<p>! Wrong: Assembly jaws are not set in place correctly.</p> 	<p>Right: Assembly jaws are set flush correctly.</p> 
<p>! Wrong: The bending point is too close to the joint end.</p> 	<p>Right: The tube has to be led straightly out of the joint.</p> 
<p>! Wrong: The tube is not pushed in as far as the inner stop.</p> 	<p>Right: Push the tube in until you can feel the inner stop.</p> 

CURING TIME OF LOKPREP 65G LOKRING® tube connection assembly version 00 (capillary reducing connectors)

