

# ASSEMBLY INSTRUCTIONS

Assembly of a LOKRING® NAV connection

# VULKAN LOKRING

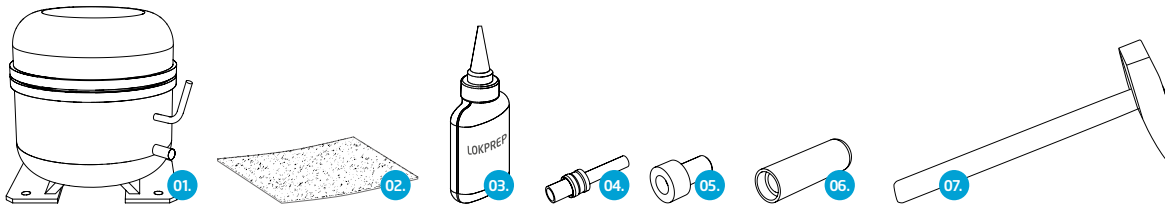

01. Compressor 02. Abrasive mat 03. LOKPREP 65G 04. NAV connection 05. NAV assembly insert 06. NAV assembly tool 07. Hammer

**1** The compressor stub length ( $X^1$ ) cannot be longer than the flared section ( $Y^1$ ) of the NAV connection, and not shorter than the length of the LOKRING that is to be used ( $Y^2$ ) + 2 mm.

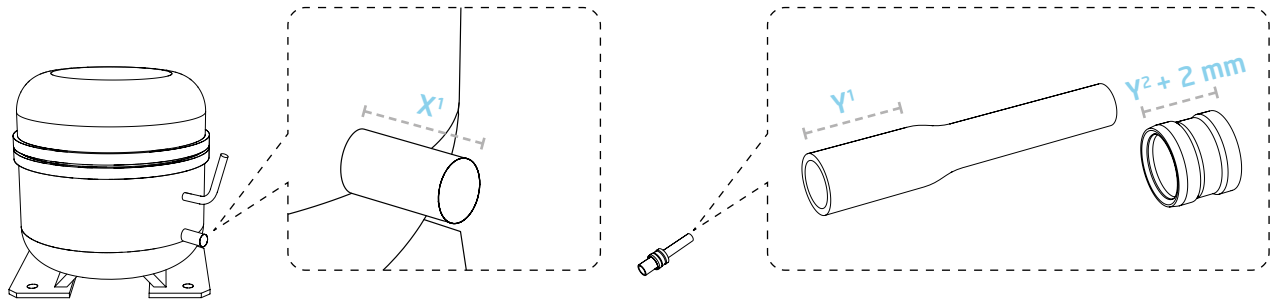

**2** Clean any paint or oil residue from the compressor stub length ( $X^1$ ) through rotational movements with the abrasive mat (02).

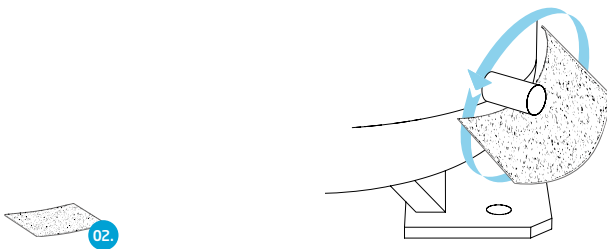

**3** Apply LOKPREP 65G (03) onto the entire circumference of the compressor stub length ( $X^1$ ), up to the cut edge. Note the curing time for the LOKPREP.

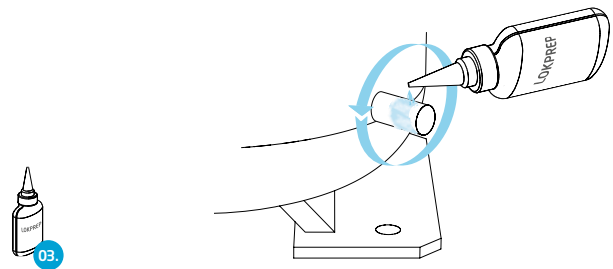

**4** **1** Insert the NAV connection (04) into the compressor stub (01). Select a NAV assembly insert (05) with the corresponding diameter, and insert this into the NAV assembly tool (06).

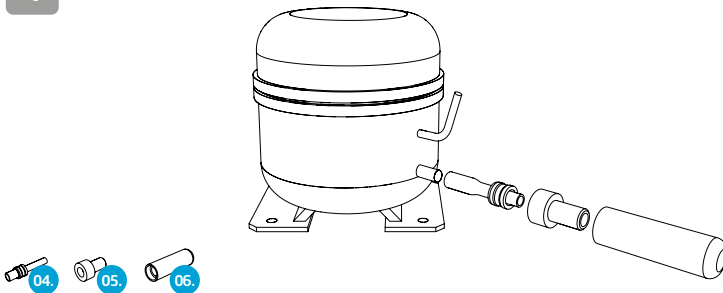

**6** Carry out the LOKRING assembly with due regard to the LOKRING Type 00 assembly instructions at [www.vulkan.com](http://www.vulkan.com).

